

Development of bell type water well with wide gravel filter

Krishna Kayastha

Kyiv National University of Construction and Architecture,
Povitroflotskyi Prospect, 31, Kyiv, Ukraine, 03680, e-mail: kriskaes@gmail.com

Summary. The purpose of this article is to present a new bell type water well construction with a wide gravel filter and its application. The construction of the water well has been developed and research has been conducted using physical and electrical modelling as well as in the practical field. Researches in this work are of analytical and experimental character. As the results of the research, optimal physical parameters of the constructions have been found and analytical – empirical formulae have been derived to calculate hydraulic parameters. Recommendation for application has been presented. The results received in this work can be used for the application of well construction. Further research is required to improve the physical and the hydraulic parameters of the proposed construction. The work has scientific and practical interest.

Key words: electrical and physical modelling, water well construction, ground water, bell type water well, water supply, irrigation.

INTRODUCTION

In the context of widespread growth of population, and industrial and agricultural production, water demand for drinking purposes, irrigation, etc. has been constantly increasing. Ground water is playing a major role in meeting these needs. Groundwater is extracted through different types of wells. To meet such needs, generally water wells are constructed with steel screens which are very expensive. If the geological condition of the construction site is of consolidated earth or rocks above the aquifer, the water well can

be constructed without the costly screen which is called as filter less well. These wells have high unit discharge, and less operation cost. In this case the water intake is formed under hard ground or rock which is above the water bearing aquifer. However, this construction can only be used if the well consolidated subsoil or rock is available. In the unconsolidated soil or sandy soil these constructions cannot be designed [1, 2].

AIM

The aim of the article is to illustrate the new bell type water well construction and its efficiency which can be applied in any geological condition.

Creation of new type water well. Colmatage is the serious problem in the well of traditional construction [3]. Wide gravel packing contributes significantly to the discharge of the well [4]. Considering these facts the study of the traditional wells constructions with screen and without it has been conducted to find out not costly well construction that is hydraulically efficient. This study led to the creation of the new bell type water well (BWW) with wide gravel screen (Fig. 1). It has less hydraulic resistance, less metal content and can be applied in a confined as well as in non confined aquifer. The funnel of the bell type water well functions as the intake. It is lowered into the well and

wide gravel is filled around it to act as a filter (Fig. 1).

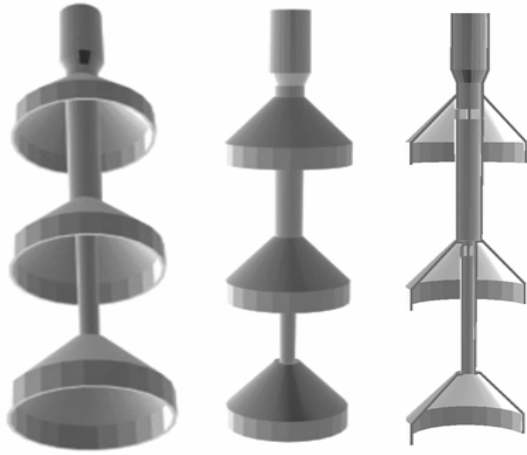

Fig. 1. Three-dimensional Model of Bell type Water Well Construction (BWW)

The vast majority of remote area populations consume low quality water and most of this population uses the traditional dug type open water well [5, 6]. These traditional wells can be replaced with the BWW where the well is protected from surface water contamination and the modern drilling technology allows the construction of such wells in different types of subsoil [7, 8].

Research has been conducted with electrical modelling, physical modelling and in the field in order to study the BWW. These studies included an assessment of the hydraulic and physical parameters of the wells with one, two and three tiers of bell type intake including the estimation methodology of the well discharge and suffusion processes. The well might be of the single or multilayer and might be constructed in a confined or non-confined aquifer. From these wells an average discharge of 200 to 300 m³/day can be obtained. The construction of the well can be made using cheap materials like PVC pipe, concrete pipe, gravel, etc. (while in the construction of the traditional wells, costly stainless steel and non-ferrous metals were required). It opens new perspectives in the design of water well for the drinking water as well as irrigation in the agricultural systems

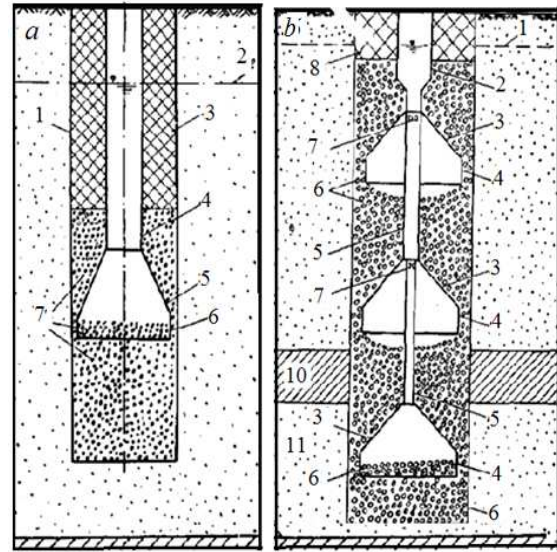

Fig. 2. Bell type Water Well Construction (BWW): *a* – Single Tier Construction, *b* – Multi Tier Construction

especially in the countries where the ground water development is taking rapid speed like in Nepal, India, and Bangladesh etc. [9, 10, and 11].

Single-tier bell type water well construction is designed to withdraw the groundwater from unconfined and confined aquifer of different level of water pressure. The geology of the aquifer or the above the aquifer may be composed of loose sandy deposits or compact soil and hard rock. Unlike in the traditional water well construction, in the BWW well, the metal screen is not used, and the use of metal is minimized. All the construction can be made with low cost plastic pipes or other local materials such as reinforced cement, concrete, wood or bamboo. The hydraulic resistance of the construction is not high. The lower water intake part is made of cylindrical funnel type and filled with gravel around the intake. The BWW (Fig. 2, *a*) consists of one large diameter trunk (600...1200 mm), gravel packing, casing 4, funnel 5 with a cylindrical edge 6 which is descended below the ground water level 2, and waterproof packing material 3. The gravel pack is filled around the cylindrical intake. The form of funnel intake bears the underground earth pressure and its ex-

tended lower part increases the area of infiltration.

Gravel pack around the cylindrical portion of the intake has sufficient mass resulting in high filtration rate and increasing the well discharge. The gravel pack stops the sand particles from entering the water, delivery pipe, and pump. Ground water flows through the gravel packing 7 to the flat bottom part of cylindrical intake and is raised to the well delivery pipe. The water is withdrawn with the well pump that is fixed below the groundwater level 2.

The multi-tier bell type water well construction is designed with a number of wide cylindrical water intakes connected with simple pipes and filled with packed gravel around the intakes. Multi-tier well structures can be used in confined 11 or unconfined 9, single or multi layer water-bearing strata (Fig. 2, *b*).

The multi-tier BWW (Fig. 2, *b*) consists of one large diameter trunk (600...1200 mm), gravel packing 6, casing 2, funnel 3 with a cylindrical edge which is descended below the ground water level 1, and connecting pipes 5 with openings 7, waterproof packing material 8. The gravel pack 6 is filled around the cylindrical intakes. The form of funnel intake bears the underground earth pressure and its extended lower part increases area of infiltration.

The cylindrical water intakes are placed in the water bearing aquifers (in these case, multi layers aquifers) which allows water to be withdrawn uniformly from the water bearing aquifers. The intakes are not placed in the impermeable layer 10. Ground water flows through the gravel packing 6 to the flat bottom part of cylindrical intakes and is raised to the well delivery pipe. The water is withdrawn with the well pump that is fixed below the groundwater level 1.

Methods of improvement of hydraulic efficiency. Fig. 3 shows the further developed BWW in which hydraulic parameters are more efficient. Fig. 3a shows a BWW construction where instead of simple blind pipes, perforated or slotted pipes 1 are used to connect the cylindrical intakes. The mate-

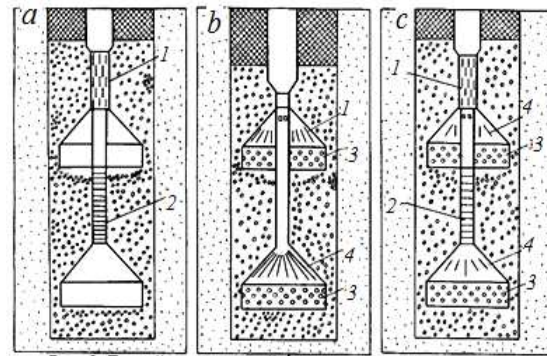

Fig. 3. Bell type Water Well Construction: *a* – with perforated screen, *b* – with perforated conic part, *c* – with perforated screen and conic part

rials of the connecting pipes and the cylindrical intakes might be different. In this case, the water intake area is higher than in the simple BWW designs, and respectively has less hydraulic resistance.

Fig. 3, *b* shows another updated construction where the funnels are perforated 3 or slotted 4. Fig. 3, *c* is given another updated multi-tiered BWW where all the parts of the constructions are perforated 3 or slotted 4. The wells of this design have maximum water intake surface area and flow rate. In this case the performance of the gravel pack is increased significantly. This is the most hydraulically efficient construction.

In the updated BWW, in place of perforated or slotted connecting pipes 2, a porous cement concrete pipe can be used. The efficiency of the porous concrete pipes can be enhanced using multiply layers of properly selected gravels of different sizes. The size of the gravels of concrete depends upon the size of the sand particles in the aquifer.

Application of bell type water well to purify ground water and to rehabilitate the well. Today many regions in the world are facing serious problems, due to the high content of iron in groundwater [12]. Backwashing methods have been using to remove iron from ground water [13]. The multi-tier BWW construction for wells with the wide gravel filter can be used to remove iron from groundwater directly in the aquifer by nonchemical circulation methods (Fig. 4). In this method the state of the iron content is

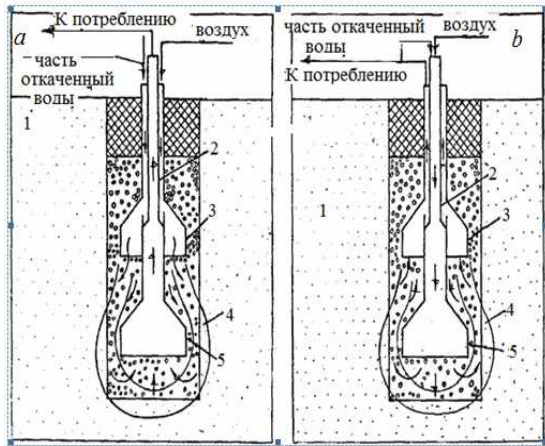

Fig. 4. De-Ironing of Ground Water in Aquifer with BWW:
a – injecting through upper intake, *b* – injecting through lower intake

transformed from a dissolved state to an insoluble form by injection of aerated, oxygen-saturated in the circulation zone of aquifer. The insoluble forms of iron will be held underground by the porous rocks or gravel pack when pumping water.

The basic idea of removing ground water iron with multi-tier BWW with gravel filter is, one cylindrical intake is used for injecting the oxidant and other intakes are used to pump out the treated water (Fig. 4). The same principle can be applied to remove the chemical colmatages from the well and other rehabilitation works.

Foldable bell type water wells. It is difficult and sometimes impossible to drill deep

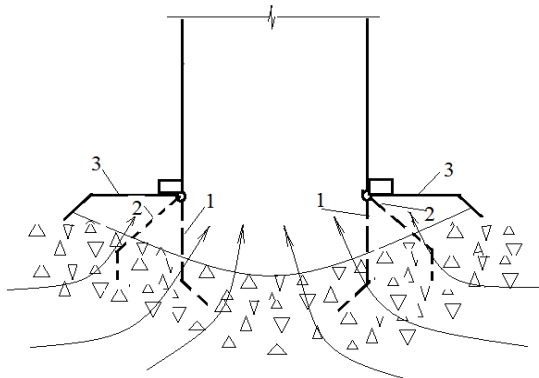

Fig. 5. Foldable Water Intake of BWW:
1 – Initial position of the conic part, *2* – Middle position of the conic part, *3* – Final position of the conic part

water wells with large diameters. In the practice of deep water well drilling of large diameters, generally the well is drilled with a small diameter just enough for casing pipe. And the well is drilled widely only in the portion of where the water well screen is placed. Similarly in the case of drilling of deep well the foldable BWW well can be applied where the water intake cylindrical part is unfolded into the aquifer. After lowering the intake of well to a point where the diameter of the well is wide enough for the construction, the water intake is unfolded (Fig. 5, 6).

Study the BWW with the method of elektrohydrodynamics analogy (EHDA). The method is based on the analogy of differential equations for potential distribution on electrically conductive paper and fluid motion in porous media [14]. The Research works of the BWW have been carried out using known methods of simulation of axis symmetric filtration in electricity conductive paper models (EHDA) proposed by P.F. Filchakov [15, 16]. Simulation of axis symmetric filtration in the electrical model can be presented by the Laplace equation given below, which describes the stationary distribution of water pressure in the filter area and the potential distribution in the electrically conductive paper.

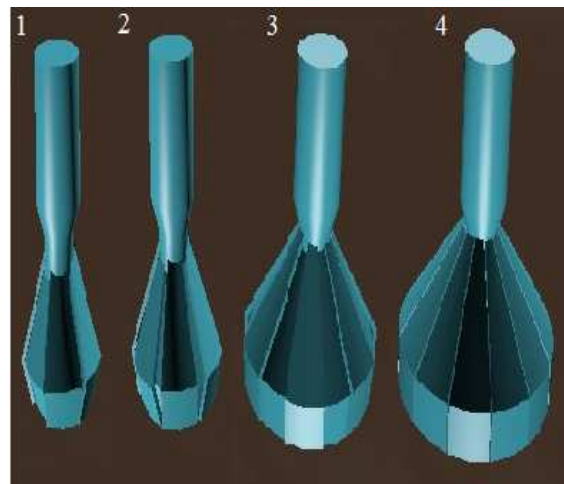

Fig. 6. Three-dimensional Model of Foldable BWW Construction: *1* – Initial position, *2, 3* – Middle positions, *4* – Final position

$$\frac{\partial}{\partial r} \left(K r \frac{\partial H}{\partial r} \right) + \frac{\partial}{\partial z} \left(K r \frac{\partial H}{\partial z} \right) = 0, \quad (1)$$

where $H = H(r, z)$ – the filter head; r, z – Cylindrical coordinates; K – Permeability coefficient of the aquifer. Then equation (1) describes the two dimensional filtration, and it can be simulated in the electric conductivity model. If we take $K \cdot r$ as a variable coefficient of filtration, the electrical conductivity should follow the laws:

$$\sigma_z = \text{const}, \quad \sigma_r = Kr, \quad (2)$$

where σ_z , and σ_r – specific electrical conductivity in the vertical and horizontal directions, respectively.

To set the electric conductivity according to equation (2), it is necessary to make the model attach several sheets different length of electrically conductive papers. The length of the lower sheet of paper must be equal to the length of the entire model. The following list is attached on the top of it and must be shorter than the value of:

$$\Delta r_2 = M \left(\frac{1}{R_1} + \frac{1}{2} \frac{1}{R_2} \right), \quad (3)$$

Each subsequent sheet must be attached on the top of it and must be shorter than the value of:

$$\Delta r_i = \left(\frac{1}{R_{i-1}} + \frac{1}{R_i} \right) \frac{M}{2}, \quad (4)$$

Where M – coefficient of proportionality which is selected as per the convenience of modelling and taken equal to $M = 4000$; R_i – resistance of the i -th sheet of paper on the square cm, $i = 3, 4, \dots, n$; n – the number of sheets. Basic research models for single-tier and multi-tier BWW are shown in Figures 7, *a* and 7, *b*. In order to reduce the model scale errors the water intake area is made in the

larger scale without distorting the picture of axis symmetric filtration.

The construction parameters and simulation options of the wells. To evaluate the performances of well constructions, research has been carried out in the electric conductive paper model using elektrohydrodynamics analogy method (EHDA) changing different physical and hydraulic parameters of the well construction and the aquifer (Fig. 8). The physical and hydraulic parameters of the construction are radii of the water intake and gravel packing r , the depth of immersion of the upper water intake c , depth gravel packing h , the distance between the water intakes b , and resistance gravel packing R_{gr} . The thickness of the aquifer m , is kept constant in the model and was equal to 200 mm (see Fig. 7). All the experiments are carried out bringing the relative parameters to the thickness of the aquifer.

$$\bar{r} = r/m, \quad \bar{h} = h/m, \quad \bar{c} = c/m, \quad \bar{b} = b/m.$$

In the experiment, the relative conductivity resistance of the gravel packing was brought to the ratio of the conductivity resistance of the aquifer R_{aq} :

$$\bar{R} = R_{aq} / R_{gr}.$$

In the experiments the dimensionless parameters were changed, in the following ranges:

$$\bar{r} = 0.05 \dots 0.015; \quad \bar{h} = 0 \dots 1; \quad \bar{c} = 0 \dots 0.3; \\ \bar{R} = 10 \dots 50.$$

Effect of the water intake positions and the dimensions of the gravel packing on the well discharge. Optimal depths of the intake for different \bar{c}_{on} , and different \bar{r} , were experimentally determined. The experimental data was mathematically processed and the following empirical formula was derived to determine the optimal depth of the intake as the function of the radius of the intake.

$$\bar{c}_{on} = 0,418 + 0,146 \lg \bar{r}, \quad (5)$$

To simulate gravel packing, conductive papers were used which have resistances 10, 20, 30, 40 and 50 times smaller than the resistance of the paper simulating the aquifer. Based on the experiments, the discharge curves are plotted as a function of the water intake radii, and the resistance of the gravel

packing. The experiment shows the significant effect of gravel packing on the well discharge (Fig. 9). The Fig. 9 shows the change in the nature of the flow rate at different radii of intake and the different resistances of gravel packing.

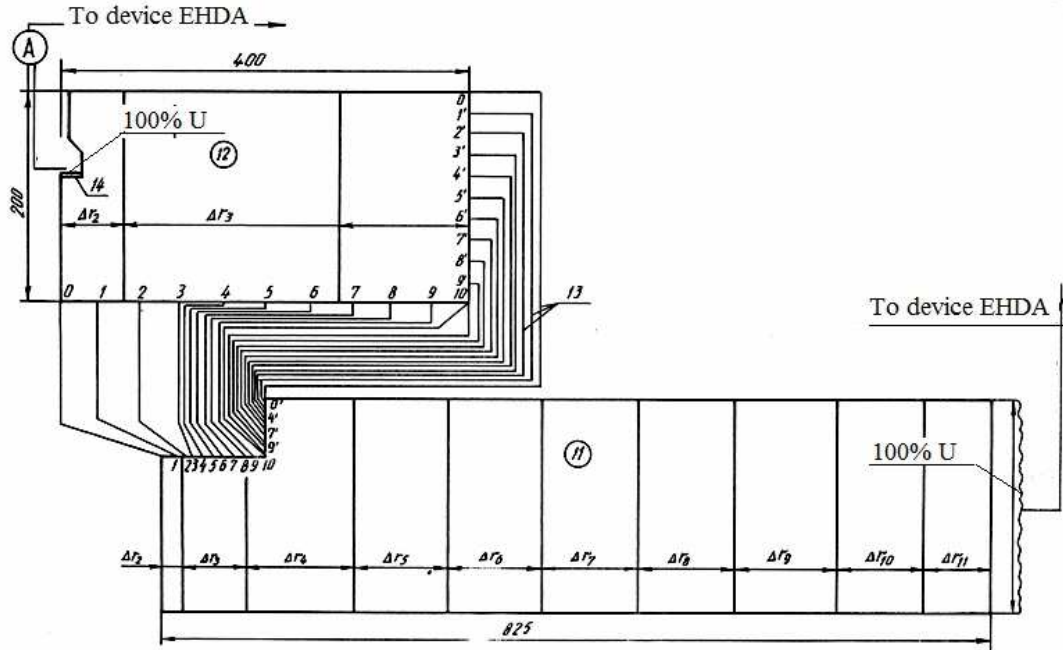

Fig. 7, a. Electrical Modelling of Single-tier BWW: 0...10 – Pin Connections, 11 – Aquifer, 12 – Intake area, 13 – Connecting cable, 14 – Current receiver, A – Amperimeter

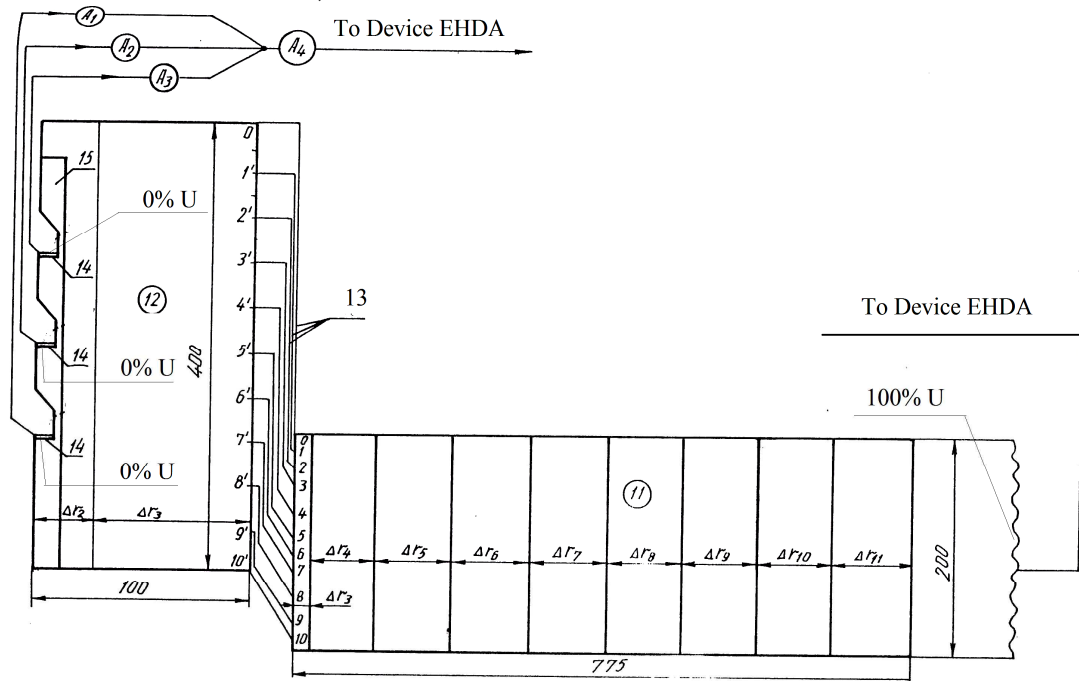

Fig. 7, b. Electrical Modelling of Multi-tier BWW: 0...10 – Pin Connections, 11 – Aquifer, 12 – Intake area, 13 – Connecting cable, 14 – Panchishin Current receiver, A – Amperimeter

Depending on the water intake position, the formula for the optimal depth of gravel packing is determined \bar{h}_{on} :

$$\bar{h}_{on} = A\bar{r}^2 + B\bar{r} + C, \quad (6)$$

The coefficients for different values of the relative resistances are given in Tab. 1.

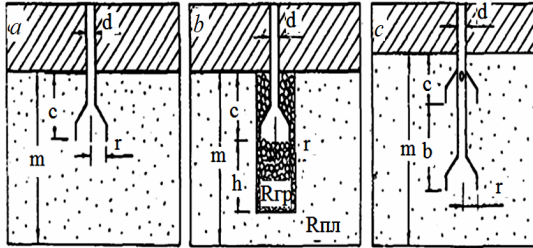

Fig. 8. Bell type Water Well Construction: a – one tiered without gravel filter; b – two tiered with gravel filter; c – two tiered without gravel filter

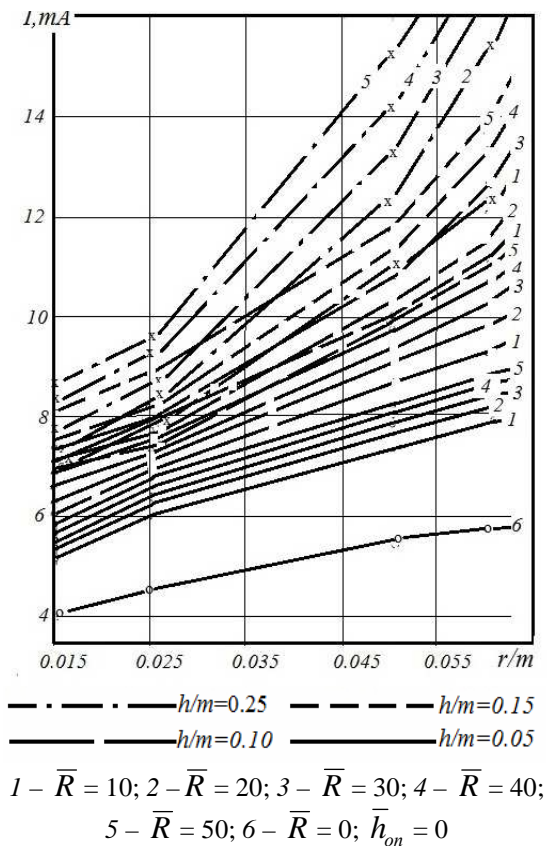

Fig. 9. Current Flow depending upon different resistance of gravel pack of the aquifer and the radius of the water intake

Table 1. Coefficients *A*, *B*, *C*, on different relative resistances for the calculation of the optimal depth of gravel packing

\bar{R}	<i>A</i>	<i>B</i>	<i>C</i>
10	97,14	-2,88	0,101
20	91,43	-2,66	0,124
30	62,86	-0,514	0,109
40	109,14	-2,87	0,148
50	120,57	-3,12	0,165

Electro hydrodynamic flow net analysis. Analysis of the influence of the nature of filtration to the discharge of the well of un-traditional type is very important. EHDA experimental setup is used in teaching and research purposes to obtain flow nets for selected groundwater flow situations with different boundary conditions using the electrical analogy concept [17].

The hydrodynamic flow net from electrical analogy gives a visual presentation of the flow process in the aquifer and it gives a clear understanding of the processes occurring near the intake (Fig. 10). The overall picture of the flow of water to the intake area is a hemispherical-radial with a sharp de-

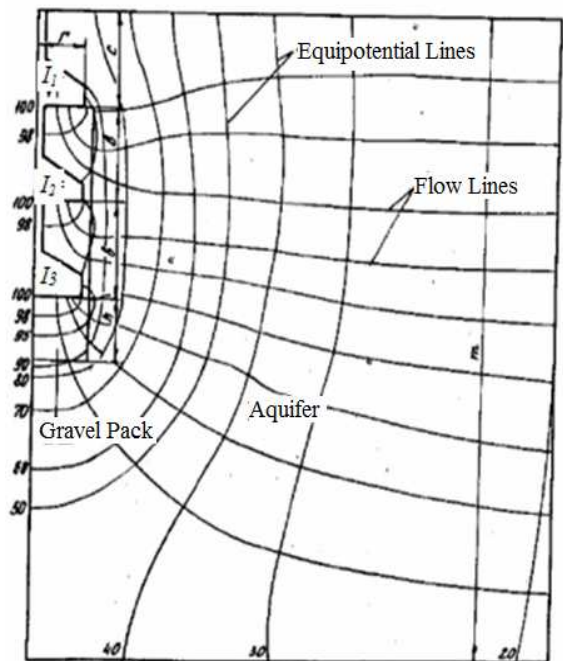

Fig. 10. Electrohydrodynamic infiltration flow net

crease in pressures (equipotential) at the cylindrical intake and smoothly flattens to the periphery of the well.

It should be noted that the main flow of water goes through the perimeter side of the cylindrical part. The central part of the intake, along the axis of the well has a small flow rate and is in the "dead" zone. This implies that the flow rate will be maximum at the wall of the intake cylinder and minimum at its centre.

Study of the well using the Physical Model. A special physical model has been built with real sand, gravel, and non-pressure water head. The study of drawdown and discharge relationship has been carried out (Fig. 11). The physical model consists of a cylindrical filtration tank 1 with a diameter of 900 mm, a height of 1200 mm which represents the aquifer. The BWW construction is placed in the centre surrounded with gravel packing 3. The water is supplied to the tank from the reservoir 12 through the pump 11. The flow energy dissipater 8 was installed to maintain the laminar flow. The water level in the tank is maintained by means of an overflow pipe 15. The discharge of the well in the model is taken via siphon 13 and supplied to a measuring tank 14 installed a triangular weir. The siphon is charged using the vacuum pump 7. The water flow in the pipeline

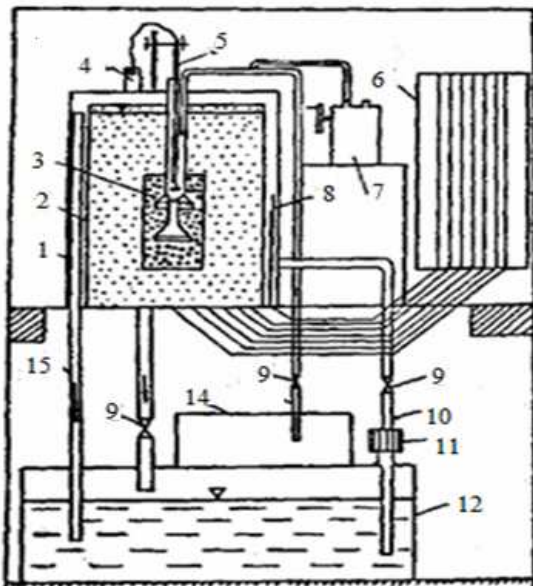

Fig. 11. Physical Model with sand and gravel

10 is regulated by the valve 9. The discharge is measured by the triangular weir of the measuring tank 14. The water levels in the intake area are recorded using piezometers 6. According to the results of research, the maximum the hydraulic resistance of the well structure is within 5...8% of the total draw-down.

Study of the discharge relationships in the multi-tier well is carried out in the hydraulic stand (Fig. 12).

Study of the wells in field conditions. In order to study in the practical field two wells of natural sizes were drilled on the northern outskirts of the city of Cherkassy, in the coastal area of the Kremenchug reservoir, Ukraine. The depth of the well is 15.85 m, drilling diameter is 720 mm. As the water intakes were installed two bell type intakes with a diameter of 620 mm cylindrical portion, connected by a pipe of 219 mm diameter and a length of 15 m. The length of each funnel is 650 mm and casing diameter 273 mm. The bottom funnel was filled with a depth of gravel 1.4 m and around the intakes and the connecting pipes also filled with the same gravel. The total depth of gravel packing is 5.5 m. A piezometer was installed in the well. Well discharge is obtained as of 6 m³ / h by draw down of level of 1.5 m, specific yield – 4 m³/h. Well depth of single-

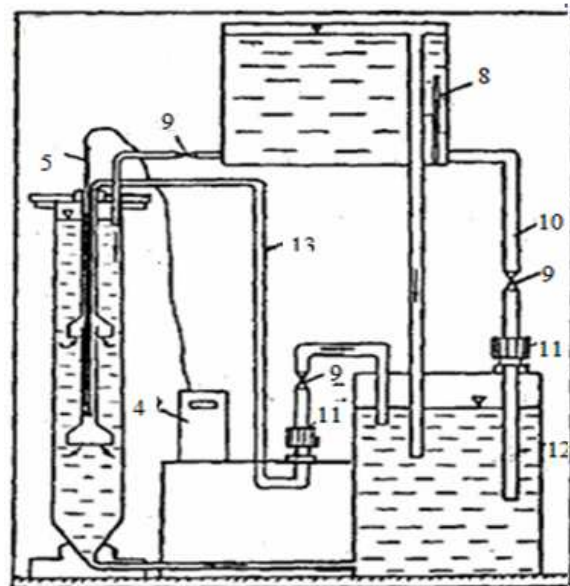

Fig. 12. Hydraulic Stand

tiered structure is 6 m, diameter 760 mm drilling. The length of the funnel is 1160 mm, diameter of the cylindrical part 620 mm. Since the lower, inside edge of the socket is concave; the edge has a diameter of 520 mm. The upper end of the funnel is welded and the casing has a diameter of 219 mm. The funnel was installed at a depth of 12.67 m and fill up with gravel with a thickness of 3.33 m.

Gravel is also filled above the funnel intake part. The total length of gravel packing is 9.5 m. A piezometer of 50 mm diameter is installed in the gravel packing. The discharge 10.1 m³/h is obtained with the drawdown of 2.22 meters. The specific flow rates of 4.6 m³/h noted with drawdown of 1.68 m. respectively 6.7 m³/h and 4 m. In both cases, the pumping was conducted for 5 hours and the water levels were stabilized after 20 minutes. In this case the water level in another well at the distance of 10.7 m was observed with a noted drawdown of 0.07 to 0.08 m.

Methods of Discharge calculations.

Considering the different natural conditions and the complex shapes of the well, the analysis of discharge is conducted, based on electric analogy models in pressure conditions. To reduce these errors to a minimum, the calculations were carried out in relative terms. For the ratio, the measurement is taken on the same model in the initial conditions. According to the theory of electrohydrodynamic analogy, the relative discharge of wells can be calculated by the following equation:

$$Q = \frac{Q_H}{Q_C} = \frac{I_H}{I_C} \xi, \quad (7)$$

Where Q_H and Q_C are the flow of imperfect and perfect wells respectively. In perfect wells, the relation of well screen length to the depth of aquifer is equal. I_H and I_C are the value of current in the model of the imperfect and perfect wells; ξ is the correction coefficient for voltage fluctuations on the model current receiver:

$$\xi = \frac{U_C}{U_H}. \quad (8)$$

Here U_C , U_H are the voltages at the current receivers of perfect and imperfect wells. The voltage of the model was fixed as a constant 20 V. Therefore, $U_C = U_H$ and hence, $\xi = 1$. Then the equation (7) comes out as:

$$Q_H = \frac{I_H}{I_C} Q_C, \quad (9)$$

Discharge of the perfect well can be determined by the Dupii formula:

$$Q = \frac{2\pi K m S}{\ln(R/r)}, \quad (10)$$

For the relative values, the denominator takes the value for a perfect well, and the numerator the value for imperfect well (BWW) working in the same environmental conditions. This value is less than one and it indicates the reduction factor of the discharge due to partial immersion of the well screen in the aquifer. To calculate the well discharge, it is necessary to know the discharge rate reduction ratio Q_H/Q_C , determined by modelling as the current reduction ratio I_H/I_C .

The value of current of the well model:

$$I_H = f(r/m, c/m, b/m, h/m), \quad (11)$$

I_H and I_C are determined by conducting experiments on EHDA models. The rest values can be extracted from Fig. 9.

In our case:

$$I = I_H.$$

The value of current as the function of the relative radius of the perfect well can be obtained by the following empirical equation:

$$I_c = 61,5\bar{r} + 17,2. \quad (12)$$

Solving the equations (9) and (10) and substituting them to the equation (12) we ob-

tain an equation for discharge calculation of the well for the condition of confined aquifer:

$$Q = \frac{2,73KmSI}{\lg(R/r) (61,5\bar{r} + 17,2)}, \quad (13)$$

where I – value of the current in the model mA; 61,5 and 17,2 – conversion coefficients from model (prototype) to real well, mA; R – radius of influence of the wells, m – depth of aquifer; K – permeability coefficient of the aquifer; values of K for Ukrainian aquifers are given in the work of Olena Voloshkina [18]; S – drawdown of the ground water level; water intake radius $\bar{r} = r/m$.

Considering the suffusion processes, the permissible discharge of the BWW can be determined by the equation:

$$Q_{perm} = 0,67 \vartheta_{perm} \pi r^2, \quad (14)$$

where 0.67 – coefficient taking into account of the uneven inflow, ϑ_{perm} – Permissible flow velocity which depends on the size of gravel package and radius r of water intake.

CONCLUSIONS

1. Bell type water wells of single tier can be used with gravel packing, and without it. The multi-tier wells must be used only with gravel packing.

2. The discharge of the wells mainly depends on the size of gravel packing, not on the number of intakes. Therefore, during the development of this design it is advisable to start with single tier intake with gravel packing of the depth of 3...5 meter for the small discharge.

3. The discharge of the single-tier well increases with the increase of the intake radius, size of gravel packing, and the immersion depth of the intake up to one third of the depth of the aquifer. Velocity for the inflow increases from the axis to the edges of the cylindrical intake (almost from zero to a maximum).

4. The discharge of the multi-tier wells increases with the distance between the intakes only up to a certain value, which is calculated depending on the radius of the intake. The water well pump should be placed between the upper and lower intakes.

5. Hydraulic resistance for the well is small and it can be used for the discharge up to 200 300 m³/day, in unconfined and confined aquifers. Application of this well design along with traditional wells will help resolve the problem of ground water supply to rural populations as a source of drinking water as well as for irrigation.

REFERENCES

1. **Malukhin N.G., Drobadenko V.P., Timoshenko S.V., Bogdanov P.V., 2010.** Features of the filter less wells construction in fine-grained rocks. Razvedka i Okhrana Nedr (Exploration and protection of mineral resources), Number: 3, All-Russian Research Institute of Mineral Raw Materials. N.M. Fedorovsk, Moscow, ISSN: 0034-026x, 38-39. (in Russian).
2. **Bogomolov G.V., Stankevich R.A., 1978.** Besfiltrovye vodozabornye skbjhiny v rykhlykh porodakh (Filter less wells in consolidated rocks). Tiorya i praktika. Theory and practice device. Minsk: Science and Technology, 152. (in Russian).
3. **Boreng R., Vikane O., Hagen T., Sorhaug E.A., 1998.** Stimulation treatment and evaluation of gravel packed well; a case study from the Statfjord Field. SPE Formation Damage Control Conference, Lafayette, Louisiana, 10.
4. **Harter T., 2003.** Water Well Design and Construction. References, The Regents of the University of California, Division of Agriculture and Natural Resources, Publication 8086, FWQP Sheet 11.3, 6.
5. **Nathaniel R., Warner N.R., Levy J., Harpp K. F., 2008.** Drinking water quality in Nepal's Kathmandu Valley: a survey and assessment of selected controlling site characteristics. Hydrogeology Journal, Vol. 16, Issue 2, 321-334.
6. **Kayastha K.P., 2015.** Skvjhiny s graviinontichnym filtrom ushirennogo kontura [Bell type Water Well with wide gravel filter pack]. National University of Water Management and Nature Resources Use, Rivne, Ukraine,

- Visnik. Collection of scientific-research work, Series 1(69), 33-49 (in Russian).
7. **Smirnov V.M., Golovan V.P., Lukyanenko V.C., 2012.** Specialne kivshove burilne obladannya z rozdilnym obertannym rizalnykh chasten ta vidchetrovym razvontajhennym nakopichuvacha. [Special bucket drilling equipment with separate rotational cutting parts and the centrifugal collectors]. *Girniči, budivelnì, dorozhni ta meliorativni mašini* [Mining, constructional, road and melioration machines], Nr79, 83-86. (in Russian).
 8. **Smirnov V.M., Golovan V.P., Konopat O.P., 2011.** Rozrabotka ta viznachena konstruktivnykh parametriv spechialnogo burilnogo ladannya dlya roboty v skladnykh gruntakh. [The development and definition of the design parameters of special drilling equipment for the complex rocks]. *Girniči, budivelnì, dorozhni ta meliorativni mašini* [Mining, constructional, road and melioration machines], Nr77, 71-76. (in Russian).
 9. **Salman M. A., 1999.** Groundwater: Legal and Policy Perspectives. World Bank Publications, Proceedings of a World Bank Seminar, Vol. 23-456, 262.
 10. **Bhandari H., Pandey S., 2006.** Economics of Groundwater Irrigation in Nepal: Some Farm-Level Evidences. *Journal of Agricultural and Applied Economics*, Vol. 38, Issue 01, 185-199.
 11. **Scott C.A., Sharma B., 2009.** Energy supply and the expansion of groundwater irrigation in the Indus Ganges Basin. *International Journal of River Basin Management*, Vol. 7, Issue 2, 119-124.
 12. **Guriovich A.D., Barymov E.B., 1982.** Obezhelezivanie vody v vodonosnykh plastakh. Deironing of water in the aquifer.. *Jhlishno kommunalmnoe khazyastvo. Housing and Communal Economy*, Minsk, Nr 6, 4 (18-19). (in Russian).
 13. **Siwiec T., Troińska J., 2007.** The influence of backwashing methods on the initial effluent quality during deironing of water, *EJPAU* 10(2), 16
 14. **Wang H.F., Anderson M.P., 1982.** Introduction to Groundwater Modeling: Finite Difference and Finite Element Methods. Academic press Inc. 237.
 15. **Filchakov L.F., 1959.** O modelirovanii osesimetricznykh potencialnykh polei na elektroprovodnoi bumage. Modeling of axis symmetric potential field on the electric conductive paper. *DAS (DAH) USSR*, 5 (in Russian).
 16. **Filchakov L.F., Panchishin V.I., 1961.** Integratory EGDA, Modelirovanie potencialnykh polei na elektroprovodnoi bumage. Integrating Electrical modeling of potential fields on an electric conductive paper. Kiev, Publishing House of Ukraine Academy of Sciences, 172. (in Russian).
 17. **Murthy Kasi M., Chi Y., Padmanabhan G., 2013.** Integrating Electrical Analogy and Computer Modeling of Groundwater Flow for Teaching Flow net Concepts. *International Journal of Engineering Pedagogy*, Vol 3, Nr 4 (39-46)
 18. **Voloshkinav O., Bereznitska J., 2014.** Development of Ukraine Territory Flooding processes: Its parameters and the influence on the environmental Safety level. *Motrol. Commission of Motorization and Energetics in Agriculture*, Vol. 16, Nr 8, 127-135.

РАЗВИТИЕ СКВАЖИНЫ С
ГРАВИЙНО-ЗОНТИЧНЫМ
ФИЛЬТРОМ УШИРЕННОГО
КОНТУРА

Аннотация. Представлен новый тип водозаборной скважины с гравийно-зонтичным фильтром уширенного контура. Проведены исследования с использованием физического и электрического моделирования, а так же в полевых условиях. Найдены оптимальные физические параметры конструкций. Введены аналитические (эмпирические) формулы для расчёта гидравлических параметров, представлены рекомендации по применению скважин с гравийно-зонтичным фильтром уширенного контура.

Ключевые слова: электрическое и физическое моделирование скважин, водозаборные скважины, подземные воды, гравийно-зонтичный фильтр, водоснабжение, орошение.