

Intelligent control system of railway transport at metallurgical plants

S. Turpak

Zaporizhzhya National Technical University; e-mail: turpak@i.ua

Received June 17 2015; accepted August 29 2015

Summary. The article deals with the transport control system at the railway transport of metallurgical plants. It has been created the intelligent control system based on the simulation of certain micrologistic enterprise system. In order to search for the most effective management decisions there are performed numerical runs of the micrologistic system simulation model at changing parameters of its work in certain ranges. Initial parameters are determined analytically or with the help of traditional methods. Decisions can be made at operational, medium and long-term planning, at the planned changes in the quantity and characteristics of the available resources, the development of transport infrastructure. Among the most effective according to model characteristics parameter sets expert group choose the one set, therefore optimization of the system parameters is provided. Conceptual control model of production processes and transportation of liquid iron and slag in the blast furnaces is determined. It has been developed the model of transport system with compensation of the influences of other subsystems and external factors on these processes. It has been created typical transport system simulation models of liquid iron and slag transfer; structure logic, control of processes and peculiarities of individual objects are presented. Models consist of standardized elements that perform certain operations for service of orders in the system. It is provided the possibility of further development of the basic models for increasing of the detailing level and advanced control logic. The influence of other subsystems on the transport system is taken into account by the withdrawal simulation of locomotives for these traffics. By the example of metallurgical plant it has been carried out the analysis of the efficiency of transport control system based on the developed models.

Key words: rail transport, metallurgical plant, simulation model, control system, transport system, optimization.

INTRODUCTION

A significant number of factors effects on the operation of the railway transport of metallurgical plants (RTMP) that makes control of the operation to be a complex problem and its solution with the help of existing automated control systems does not allow to use the resources of transport system in the most efficient way.

THE ANALYSIS OF RECENT RESEARCHES AND PUBLICATIONS

Metallurgy is one of the leading Ukrainian sectors, the most attractive for investors [1-5].

At the transport of metallurgical plants logistic approach to the improving of its operation for an effective and qualitative production service is widely used [6-10].

For determination of the optimal parameters of the transport systems at metallurgical plants a number of traditional approaches and methods are used [11-15]. The efficient use of these methods is limited by the requirements of the actual conditions and the inability of taking into account of all the factors that effect on the transport system operation [16-18]. One promising way is the using of modern universal methods, including simulation modeling [19-22].

Intelligent control systems based on simulation models of micrologistic systems (MLS) of the rail transport at metallurgical plants allow to find close to optimal, maximally effective solution concerning the distribution of available resources and the usage of the enterprise transport infrastructure.

Such solutions can be found at operational, medium and long-term planning (under conditions of the planned changes in the number and/or characteristics of the available resources, development of transport infrastructure, etc.).

OBJECTIVES

The goal of the paper is to create effective intelligent control systems based on simulation models of micrologistic systems operation at metallurgical plants.

THE MAIN RESULTS OF THE RESEARCH

Structurally intelligent control system based on simulation model of micrologistic system of rail transport at metallurgical plants is presented in Fig.1.

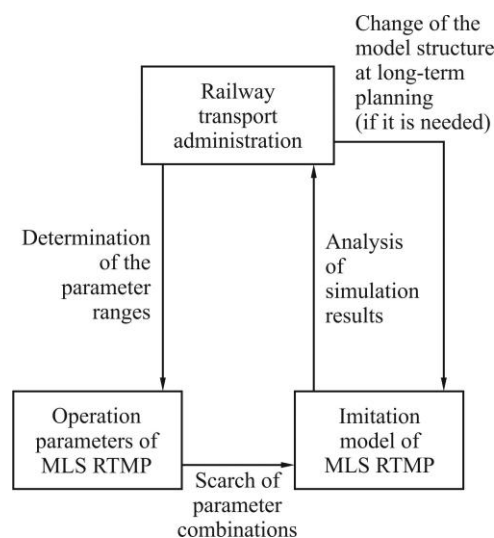

Fig. 1. Intelligent control system of MLS RTMP

Presented intelligent control system operates as follows. Staff of the Enterprise railway transport administration determines the approximate, close to optimal parameters of individual components and subsystems functioning of MLS RTMP.

To search the most effective solutions the one execute runs of the MLS RTMP simulation model when changing the parameters of its operation in some ranges from defined analytically.

Among the most effective according to the model characteristics parameter sets expert group choose the one. This provides optimization of the system parameters.

Let's examine the use of intelligent control system for improving of the liquid iron and slag transport by rail, which processes are typical at many metallurgical plants (granulation at blast furnace is not considered).

Composition of conceptual model of MLS traffic starts from representation of material flow of liquid iron and slag from furnaces.

Fig. 2 shows a conceptual control model of blast furnace production processes of cast iron and slag.

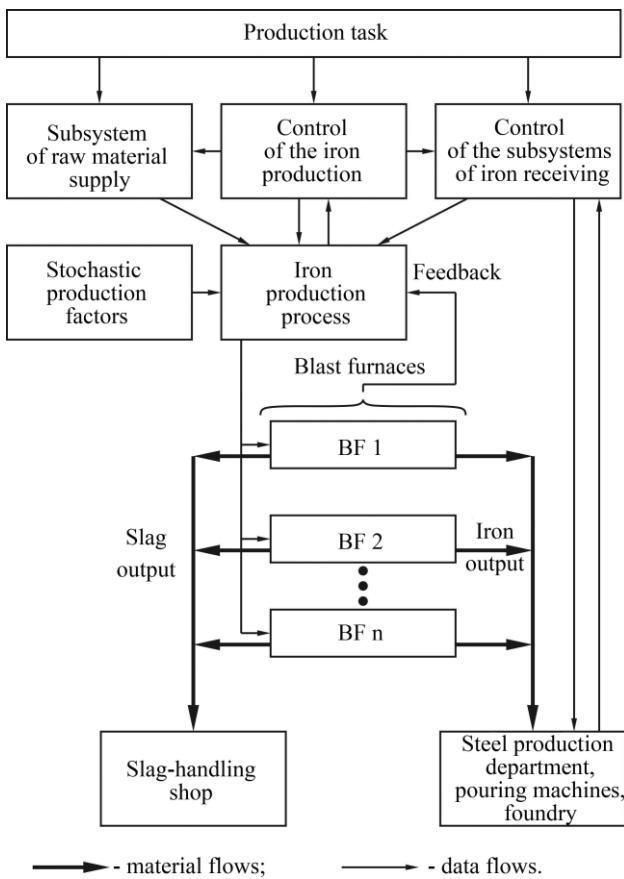

Fig. 2. Conceptual control model of iron and slag production processes in blast furnaces

This model takes into account an influence of other subsystems and external factors in the RTMP system.

In simplified form, the model looks as follows (Fig. 3).

The influence of other subsystems and external factors is compensated by generation of iron production with a certain distribution of random variable.

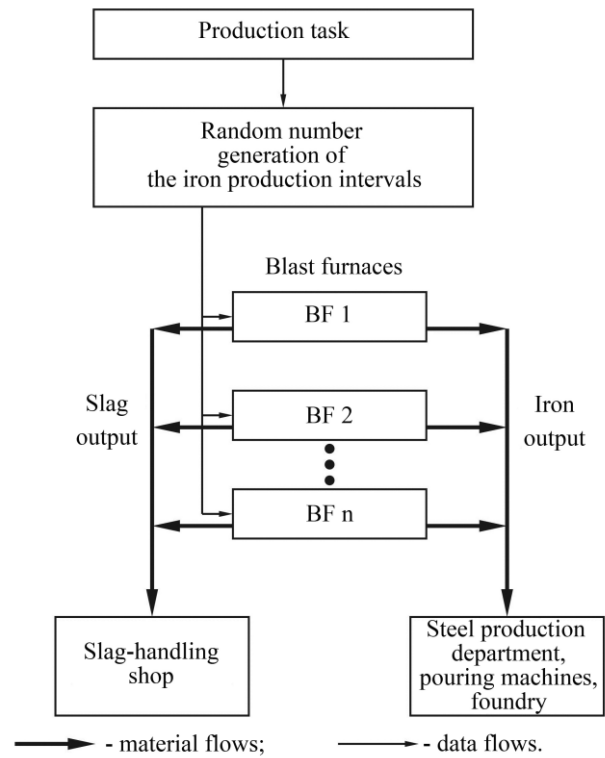

Fig. 3. Model of transport system operation with compensation of the influences of other subsystems and external factors on the production processes of iron and slag

A simulation model can be made of standardized elements that perform certain operations in service of orders in the system.

Logic explanation of the model structure of liquid slag transport is convenient to carry out by example of liquid iron transportation.

In Fig.4 typical simulation model of the transport system of the liquid iron traffic is shown.

Model consists of the following standardized elements: 1 – order generator; 2 – service queue; 3 – capture of the moving and movable resources; 4 – capture of the stationary resources; 5 – service unit of orders; 6 – eliminator of orders.

According to the presented model order is request of capture and moving of two types of resources: P – movable (ladles) and R – moving (locomotives).

Orders are in queue before the appearance of free resources. After their capture (element 3), the direction of order movement to the service units is determined. Service units simulate operation of the weight systems (service occurs during the time t_{zv1}, t_{zv2}) and end-users, such as foundry, mixer department and filling machines (service occurs during the time $t_{zj1}, t_{zj2}, t_{zj3}$)

During movement the order captures stationary resources (type C), that simulate some parts of the railway lines. Sections are determined with taking into consideration the negation of simultaneous occurrence of more than one order on them.

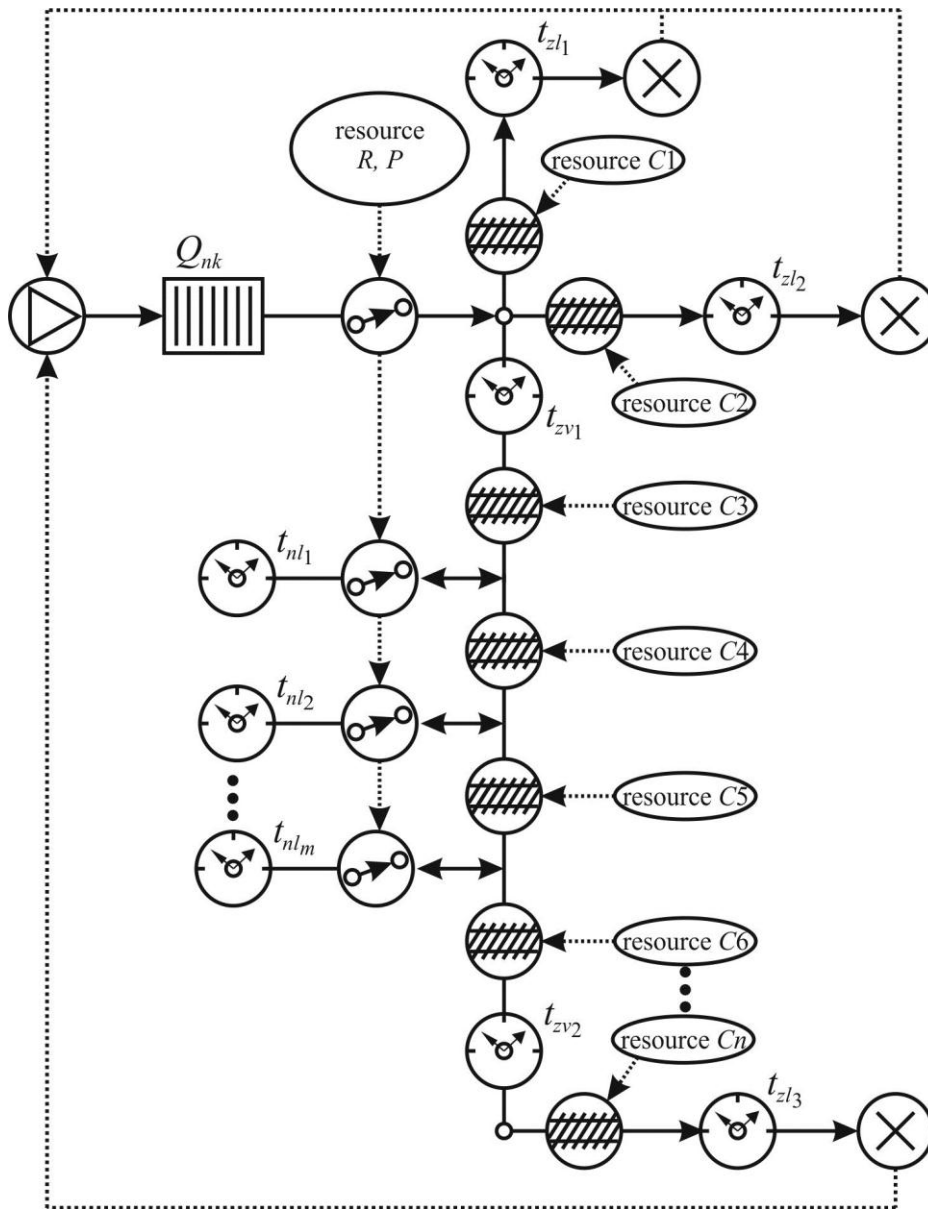

Fig. 4. Typical simulation model of the transport system of the liquid iron traffic

It is considered that if the orders move towards each other in the joining places they are able to pass each other (in fact, it is done by stopover of the iron pouring in the direction of railway lines etc.). That is, reaching the border area (which can be simulated by creation of the transport network model or delay of request in time needed for passing of the area); orders release the appropriate resource that can connect to another one, including a counter-order.

After the elimination of the orders (iron is considered to be transferred to the corresponding part of the production process), resources wait for the next capture of the new orders.

This algorithm involves cyclic creation of orders for a certain period before their first service (pouring of the liquid iron) during time $t_{nl1}, t_{nl1}, \dots, t_{nlm}$. But the order can be created at the time the movable resources (ladles) are released. Actually, the supervisor can plan the usage of the empty ladles, even if the need in them has not yet been determined.

In this case, the structure of the simulation model of the liquid iron transfer transport system will look as follows (Figure 5).

In such a model structure, new orders are generated by the elimination of pre-served orders. It is clear that for the system run the single formation of several orders is needed.

For new orders for the respective model logic service unit (blast furnace) is chosen. The choice can be made according to the smallest time prior to the iron production or the more close match of the released resources number (at elimination of the processed orders), needed for the furnace.

Orders capture free movable and moving resources (ladles and locomotives) and move with them, sequentially capturing the stationary resources (sections of the railway lines).

Reaching a given service unit, orders release moving resources (locomotives) during time $t_{nl1}, t_{nl1}, \dots, t_{nl}$ (Fig. 5), and hold movable resources (ladles) after service.

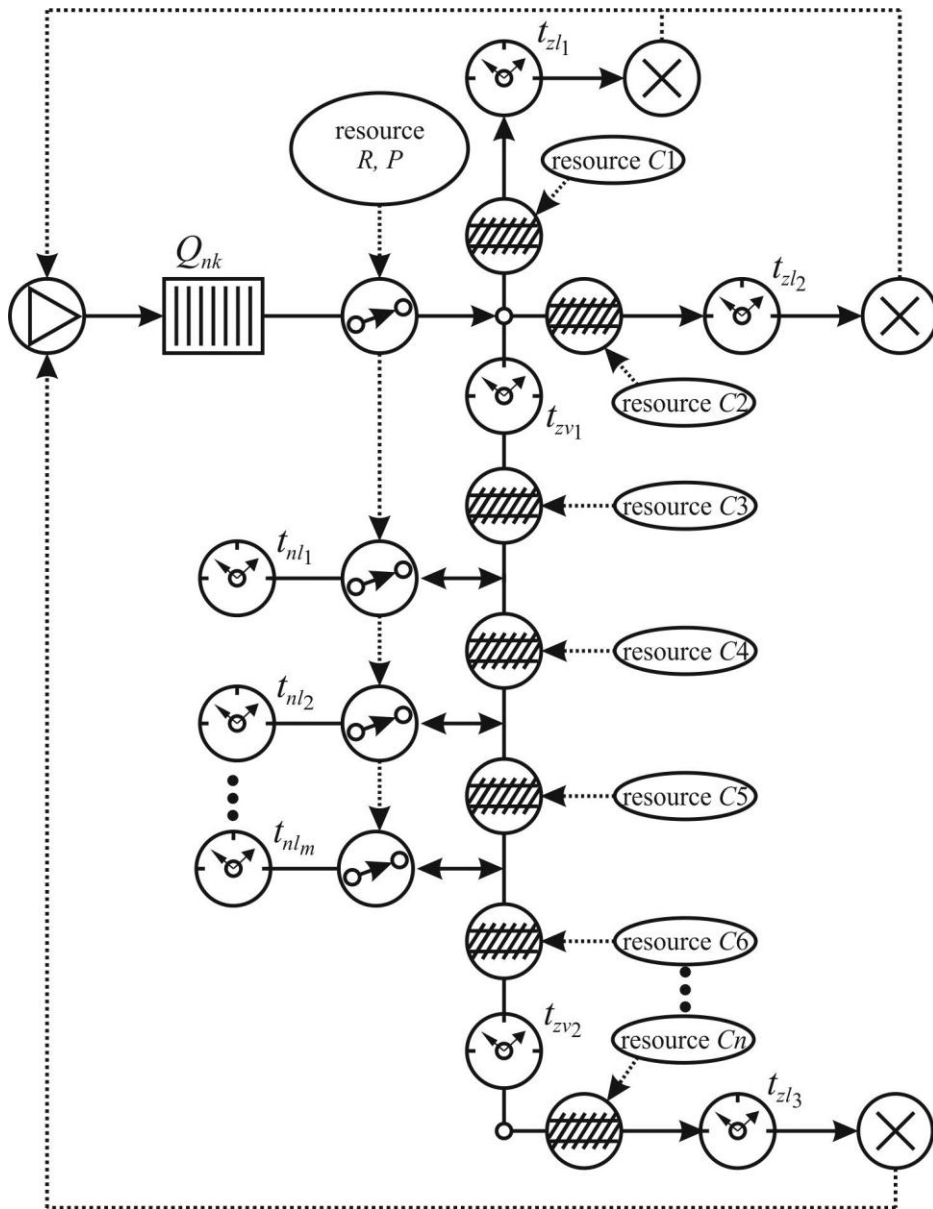

Fig. 5. Improved simulation model of the transport system of the liquid iron traffic

After the first service order again captures the moving resource (locomotive) and moves to the next units that simulate weighting (during time t_{zv1} , t_{zv2} – usually two weight units are used) and pouring in of liquid iron (during t_{zl1} , t_{zl2} , t_{zl3} – according to the foundry performance, mixer department or filling machines). At transfer of orders to the units moving resources are released. Duration of the cargo handling can be defined by analytical calculations or generation by a pre-chosen theoretical distribution law of a random variable.

After this service, orders are eliminated, and resources that they have held (lands) are released. At elimination new requests are formed by order generator and work cycle repeats again.

Basic models can be developed, reaching a deeper level of detailing and more advanced control logic.

Thus, in modeling of the furnace it may be considered the presence of a sloping bath which lets to perform a movement of the main batch of ladles by temporary directing of the molten metal flow to a separate ladle. It can be provided certain cycles of removing of this

ladle with taking into account the principle of filling to load capacity and restriction of the iron hardening time.

It can also be considered the use of reserve ladles, which with some probability can be filled with iron.

The influence of other subsystems on the transport system, such as pig iron transfer, is taken into account by the need of withdrawal of these locomotives for these traffics. Typically, the "cold" side of filling machines is a separate shunting area and its service does not affect the use of other resources in the system of liquid iron transportation (ladles and section of the railway lines along which they move).

Transportation of liquid blast furnace slag differs from the transportation of liquid iron by train formation from several furnace melts. Each train is transported by a separate locomotive that serves them at one or more pouring station.

The basic structure of the simulation model of the liquid slag transport system is shown in Fig. 6.

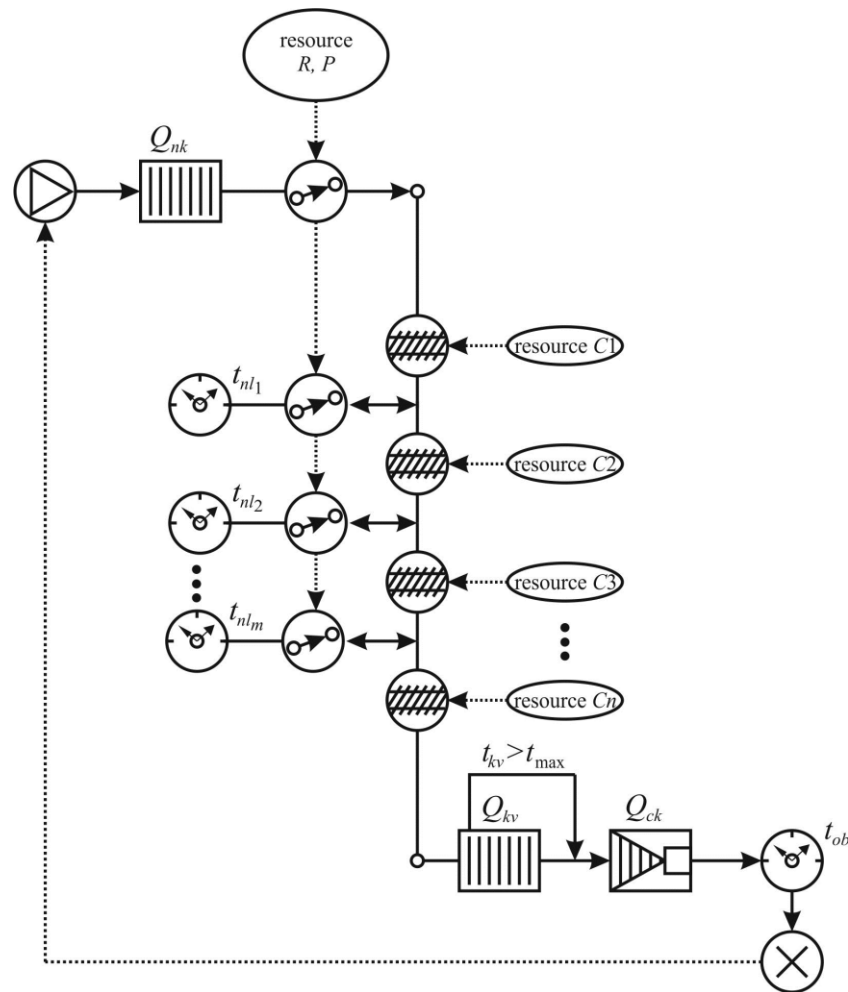

Fig. 6. Typical simulation model of the transport system of the liquid slag traffic

The difference between this model from the one, showed in Fig. 5 is the presence of elements marked with symbols Q_{kv} and Q_{ck} . The first one is the queue of ladles with the load, the second – simulates the train formation for departure.

Train formation is based on achieving in queue Q_{kv} such a number of ladles that meets or exceeds the estimated train size Q_{ck} for departure (according to the tractive calculations).

In addition, the train is formed from the current number of ladles, if the duration of their idle time in a loaded condition exceeds the maximum permissible value $t_{kv} > t_{max}$.

Train turnover can be presented in detail by operations:

- motion to the granulation pool;
- shunting operation of ladle setting to the front of slag pouring;
- pouring of ladles into the pool;
- train formation;
- train motion to the heap;
- shunting operation of ladle setting to the front of slag leaving;
- draining of residues and leaving of ladles;
- formation of train with empty ladles;
- train movement to the load station;
- spraying of the inner surfaces of ladles;
- acceptance operations.

It's possible to combine all the above operations and set fixed train turnover duration by generating the theoretical distribution law of a random variable.

After processing of the orders they are eliminated and new orders are called in.

Thus, in the transport system model of the first partitioning at metallurgical plant the requests for the feeding of the empty ladles to the furnaces play the role of the orders. Required number of the movable resources (ladles) for servicing of a particular request is set as a fixed value or simulated random variable.

For transfer of the order with the captured movable resources moving resource (locomotive) is used.

Transferring of the orders along the parts of the railway lines, where crossings i.e. conflict is possible, is carried out by capturing of the stationary resources.

Practical implementation of the model can be performed using simulation. This program allows creating simulation models with the help of standard elements, observing the simulation in the form of animation processes and changing settings in an interactive mode.

Topology of a transport network is specified with a group of figures: rectangles set network nodes and lines – relations between them, which play a role of request transfer and resources in the simulated space.

Over the rail diagram transport network along which applications and resources will transfer is specified (Fig. 7).

For each group of resources used in the network it is specified the type, quantity, velocity of transfer, basic location in the network, the figure of animation and others.

"Heart" of the model is event generation unit. One of these events is required only for the start of the program (performed once during all program). It calls in four first orders for feeding of the empty ladles to the furnaces.

Each of the other four events simulates the end of slag production of the corresponding furnace №2-5.

Time of events and their actions are given in a special form, indicating that the event takes place cyclically after predetermined time. Cycle period is specified with normal distribution function of a random variable with parameters defined for each furnace.

At the specific event, the following steps are made: unlocking of the element delay of the order transfer in the relevant model branch and verification of timely location of resources (ladles) at the beginning of slag production. In case of melting failure due to the absence of ladles this fact is fixed by increasing of relevant variables for each furnace.

Each order calls in and captures free moving resource – locomotive, and then are captured with it as movable resources – ladles. Order moves along certain program branches (its structure will be discussed later) with captured resources – "locomotive" and "ladles" to the element that marks the location of the blast furnace. Resource "locomotive" is released – disconnects from the

order, and resources "ladles" remain with the order and expect event "end of melting."

As this event starts, the order with the resource "ladles" again capture resource "locomotive" for transfer in location of train formation for departure from the station, and at this moment in the model new orders for service of the blast furnace is generated.

Thus, in the model the technological process of the slag output from blast furnaces is carried out independently of the transport service – according to the schedule output considering the random nature of deviations from it.

Transport service is oriented on execution of the orders for delivering of the slag transport to the furnaces, which are formed in the system immediately after melting.

The main part of the model is divided into three blocks.

In the first block requests that capture free resource "locomotive" (in its absence, wait for it in the queue) are formed. Then due to the random variable distribution law of the ordered quantity of ladles order goes through the corresponding network element, where it is indicated how many resources should be captured.

In our case, there is provided the possibility of entering orders in the queue, not only at the capturing of required number of resource "ladles", but in the case of long-time absence of the right amount of these resources (output "at timeout"). In this case, at least one ladle is captured and an additional order to catch up their desired amount is formed.

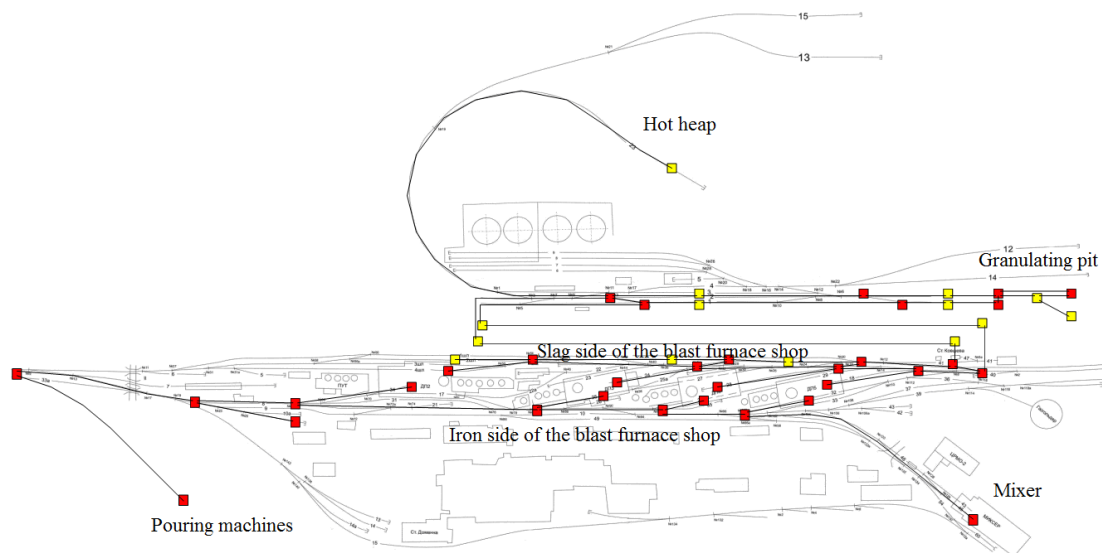

Fig. 7. Topology of a transport network

Later order is sent to the furnace, the slag output in which comes sooner than in others.

Thus, to the second program block the order comes to the appropriate service branch of the individual furnace. These branches have different order routes. As we move towards the furnace, order together with the captured resources ("locomotive" and "ladles") capture stationary resources – sections of the railway lines and move along them.

There cannot be more than one train on a separate section, i.e., one section – one individual resource. When the order comes to a new section previously captured section is released and can be captured by other orders. In case of opposing motion of order they approach to the captured sections, and when they will meet in this place, actually would be able to exchange their sections (release "its" and to capture "others").

Regarding real objects, this situation is understood as follows: the interface of the railway sections is point switch, connecting three sections therefore why one of the trains can move to a vacant place, skip the opposite train according to the switch and take the railway line, which it has vacated.

At arrival of the loaded resources – "ladles" – to the place of storage, they are emptied from the order. This order is eliminated and by the number of ladles that have moved with the eliminated order a new group of orders is formed.

These actions are necessary for implementation of the third block which provides a simulation of the movement of trains that are limited in the number of ladles and sometimes require a separation of loaded with individual furnaces groups.

In the third block of the program the size of the train is determined: when reaching the maximum size in the storage queue or when exceeding the allowable period of "ladles" location in the queue (output "at timeout"). In this block one order corresponds to one "ladle". After train formation, its size is fixed; all orders are eliminated, except the one that later captures the resources which number corresponds to the train size. Hence that left order simulates the movement of a single train with few resources – "ladles".

Order moves through the network according to the technological route, then releases all captured resources and immediately self-eliminates.

The main results of the model operation are the following characteristics:

- time of the resource "locomotives" using;
- time of the resource "ladles" using;
- the number of registered failures in the furnace operation because of the untimely delivery of ladles.

Additionally, it can be analyzed:

- time distribution from the delivery of ladles to the front of the liquid slag pouring till the start of output;
- the turnover time of trains etc.

Statistical data are gathered and displayed as diagrams..

Before each run the quantity of the resources – ladles and locomotives – are changed (increased and decreased relative to analytically calculated values).

Analysis of the results is convenient to examine at the diagram shown in Fig. 8 (darker areas correspond to higher probability of failures).

From the diagram analysis the following can be concluded:

- at usage of 5 locomotives it is needed at least 56 ladles to avoid disruptions in the operation;
- at usage of 6 locomotives it is enough 45 ladles.

Based on economic calculations the most effective variant of rolling stock application is chosen as a minimum cost for transportation.

Calculations show that the annual cost savings using this technique for optimization of a certain micrologistic enterprise systems is several million hryvnia, depending on the specific conditions.

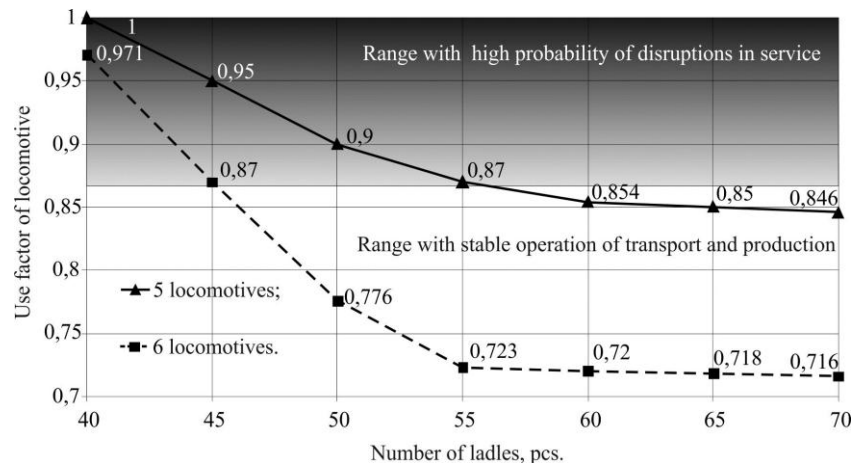

Fig. 8. Diagrams of the use factor of locomotives versus number of ladles

CONCLUSIONS

1. The developed intelligent control system of railway transport for metallurgical plants allows improving the transfer efficiency.

2. Introduced approach allows searching for the most effective management decisions at operational, medium and long-term planning.

3. Application principles of the intellectual control system are approved based on the transport system of liquid iron and slag transfer. It has been created typical

simulation models that can be used at Ukrainian and foreign metallurgical plants.

4. The possibility of further development of the basic models for increasing of the detailing level is provided.

5. Performed analysis by the example of metallurgical plant has proved the efficiency of transport control system application based on the developed models.

6. Stated technique of the practical application of the model in conditions of blast-furnace shop allowed determining of the most economical way of operation management by the effective use of locomotives and ladles.

REFERENCES

1. **Paranchuk S., Korbutyak A. 2013.**, Problems investment support innovative development of the national economy and solutions. *Econtechmod. An international quarterly journal.* 2(4). 53-60. (in Polish).
2. **Akulnichiev V. M. 1983.** Transfer organization at the industrial transport. Moscow, Russia. 247. (in Russia).
3. **Balandyuk G. S., Kurtukov Ya. M. 1985.** Technology of railway transport at metallurgical plants. Moscow, Russia. 256. (in Russia).
4. **Labadin S. I., Shmulevich M. I. 1978.** Organization and control of railway transport at metallurgical plants. Moscow, Russia. 264. (in Russia).
5. **Perepelyuk A. V., Horuzhiy A. S. 1982.** The economy of metallurgy industrial transport. Moscow, Russia. 192. (in Russia).
6. **Gubenko V. K. 2004.** Development of production-and-transport logistic systems. Pryazovskyi State Technical University. Mariupol, Ukraine. 14. 306-310. (in Ukraine).
7. **Laschenyh A. A., Turpak S. N., Gritsay S. V. 2015.** Logistic presentation of the material flow processes. *National Association of Scientists.* 2(7). 91-95. (in Russia).
8. **Turpak S. M., Gritsay S. V., Ostroglyad O. O. 2014.** Development of micrologistics system of delivery of finished products of metallurgical enterprises by rail transport. *Eastern-European Journal of Enterprise Technologies.* Kharkov, Ukraine. 5. 10-18. (in Ukraine).
9. **Parunakyan V. E., Gusev Yu. V. 2006.** Regarding formation of logistical chains in the cargo-transport systems at metallurgical plants. Pryazovskyi State Technical University. Mariupol, Ukraine. 16. 220-226. (in Ukraine).
10. **Parunakyan V. E., Boyko V. A. 2005.** Simulation of cargo traffic processing in modules of the logistical chain. Pryazovskyi State Technical University. Mariupol, Ukraine. 15. 183-185. (in Ukraine).
11. **Parunakyan V. E., Gusev Yu. V. 2005.** Logistical control of transport-cargo complexes at metallurgical plants. Pryazovskyi State Technical University. Mariupol, Ukraine. 15 (1). 177-182. (in Ukraine).
12. **Zhivitskaya H. 2014.** Topological properties and methodology of research of complex logistic systems efficiency. *Econtechmod. An international quarterly journal.* 3 (3). 23-32. (in Polish).
13. **Perepelyuk A. V., Bondarenko V. O., Mironenko A. A., 1987.** The economy of industrial transport. Moscow, Russia. 336. (in Russia).
14. **Ugryumov K. A., Romanov A. P., Miroshnichenko Z. L. 1986.** Train schedule at industrial railway transport. Kyiv, Ukraine. 208. (in Ukraine).
15. **Gusev Yu. V., Gusev D. Yu. 2008.** Mathematical model of the iron transportation process to the converter shop. Mariupol, Ukraine. 18 (1) 230-232. (in Ukraine).
16. **Karpov, Yu. G. 2005.** *Simulation modeling of systems. Introduction and modeling with Anylogic 5.* S-Petersburg, Russia, 400. (in Russia).
17. **Kozachenko D. M., Vernigora R. V., Korobova R. G. 2008.** The software package for simulation modeling of railway stations on the basis of the daily schedule. Kyiv, Ukraine. 4. 18-20. (in Ukraine).
18. **Okulov N. E., Timokhina E. N. 2014.** *Sustainability increasing of interaction between production and transport.* Transport of Ural, Russia. 2, 7-11. (in Russia).
19. **Okulov N. E., 2014.** *The methods and ways to improve the interaction between production and transport.* Ekaterinburg, Russia. 140. (in Russia).
20. **Okulov N. E., Chetverikov V. A., Kashcheeva N. V. 2014.** Research of the factory marshalling station with the help of **simulation modelling.** Transportation: science, technology and management, Russia. 3. 58-62. (in Russia).
21. **Turpak S. M. 2015.** Improvement of the simulation technique of input car traffic volumes of metallurgical enterprises. East Ukraine Volodymyr Dahl National University, Ukraine. 1. 51-56. (in Ukraine).
22. **Turpak S. M. Simulation incoming stream carriages of industrial railways. 2013.** East Ukraine Volodymyr Dahl National University, Ukraine. 5. 75-80. (in Ukraine).

ИНТЕЛЛЕКТУАЛЬНАЯ СИСТЕМА УПРАВЛЕНИЯ
ЖЕЛЕЗНОДОРОЖНЫМ ТРАНСПОРТОМ
МЕТАЛЛУРГИЧЕСКИХ ПРЕДПРИЯТИЙ

С. Турпак

Аннотация. В статье рассматривается система управления перевозками на железнодорожном транспорте металлургических предприятий. Создана интеллектуальная система управления, которая основана на имитационном моделировании работы определенной микрологистической системы предприятия. Для поиска наиболее эффективных управленческих решений выполняются многочисленные прогоны имитационной модели микрологистической системы при изменении параметров ее работы в определенных диапазонах. Начальные параметры определяются аналитическим путем, или другими, традиционными методами. Решения могут вырабатываться как при оперативном, так и при среднесрочном и долгосрочном планировании, в условиях планового изменения количества и характеристик имеющихся ресурсов, развития инфраструктуры транспорта. Среди наиболее эффективных по показателям работы модели групп параметров группой экспертов выбирается одна из них, чем обеспечивается оптимизация параметров функционирования системы. Определена концептуальная модель управления процессами выпуска и транспортирования жидкого чугуна и шлака в доменном производстве. Разработана модель работы транспортной системы с компенсацией влияния других подсистем и внешних факторов на данные процессы. Созданы типовые имитационные модели транспортной системы перевозки жидкого чугуна и шлака, приведена логика построения структуры, управления процессами и особенности функционирования отдельных объектов. Модели состоят из стандартизированных элементов, которые выполняют определенные операции по обслуживанию заказов в системе. Предусмотрено развитие базовых моделей в направлении достижения более глубокого уровня детализации и более развитой логики управления. Влияние других подсистем на работу транспортной системы учитывается путем имитации отвлечения локомотивов на эти перевозки. Выполнен анализ эффективности системы управления перевозками на базе разработанных моделей на примере металлургического предприятия.

Ключевые слова: железнодорожный транспорт, металлургическое предприятие.