

## MULTIPLE IMPACT EFFECTS OF WHEAT GRAIN\*

*Z. Ślipek, A. Złobacki*

Faculty of Engineering and Energetics in Agriculture, University of Agriculture  
Balicka 104, 30-149 Cracow, Poland

**A b s t r a c t.** This paper estimates the distribution parameters of wheat grain damage found in multiple loads. The influence of the impact on resistance to mechanical damage has been determined. The samples of 400 grains was multiple impacted with a metal plate with various speed from 14 m/s to 30 m/s up to the first visible grain damage. The moisture of grain was about 16 %. The results of statistical analyses show that the distribution of the number of loads in which the external structure is wasted are different depending upon the speed of the impacts. When the speed of the impacts are greater than 20 m/s all the data falls within one numerical parameter. As a result the multiple loads can be investigated on grains below this speed. It was stated that multiple impacts at 8 m/s causes a lower immediate resistance without changing the internal structure.

**K e y w o r d s:** wheat grain damage, multiple loads

### INTRODUCTION

In most of cases mechanical effects exerted by the operating elements of harvesting, threshing, cleaning and sorting machines constitute the factors generating mechanical damage to the grain. Damage may also come up without any external and mechanical actions, e.g., in consequence of internal stresses brought about by an intensive change in grain temperature and humidity. Therefore, in most of cases a grain already damaged is subjected to further action of a destructive factor.

The evaluation of behaviour of grain exposed to mechanical loads usually boils down to performing a load test in controlled conditions at a laboratory. The effects of such a

load appearing, for instance as damage, give the base for classifying the grain as more or less resistant to the action of loads coming up in the course of technology processes. The hitherto used laboratory methods usually provide a single load of grain [1,2,3]. Actually, it is a too big deviation from the real conditions encountered in the machines in which grain in most of cases is exposed to a series of consecutive loads necessary for carrying out a technology process. Hence, in order to bring the evaluations of laboratory tests as close to the actual loads occurring in the machines as possible it is indispensable to describe and determine the multiple loads effects caused in the controlled conditions. As yet, no relations between the multiple loads parameters and the destructive effect coming up, e.g. via damaging grains, have been known.

Thus, this paper is aimed at determining the limiting value of the grain impact velocity at which multiple loads may bring about changes in the grain internal structure, and the grain limiting impact velocity at which a superposition of those impacts will cause destruction of the grain external structure.

The test results give the grounds for further research projects comprising the problem of creation of grain mechanical damage.

\*This research was financed by the State Committee for Scientific Research, Poland under grant No. 5 01 67 9101.

## MATERIAL AND METHODS

The tests were conducted on grain laboratory samples (400 grains each) taken out by representative method of a grain mass that had been husked out of ears. Two varieties of winter wheat (Gama, Almari) and two varieties of spring wheat (Jara, Henika), different in the grain physical features, were selected for tests said. The measurements were carried out at grain moisture content of  $16\% \pm 0.5$ . Grain load dynamical tests were performed on the stand presented in Fig. 1. Its construction gives a possibility of executing free grain impacts (without any support).

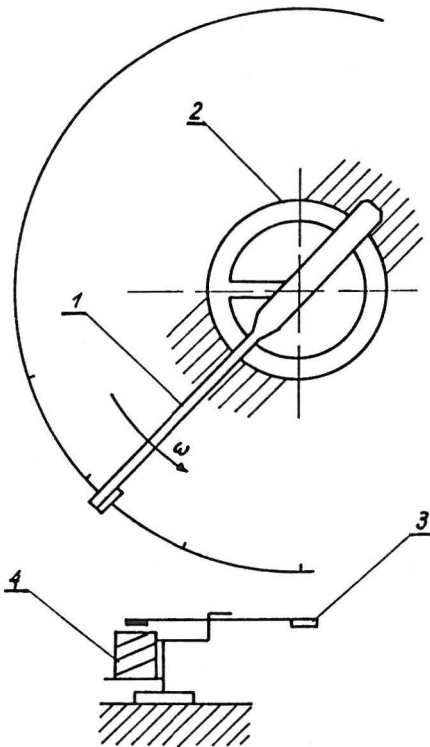

Fig. 1. Scheme of stand for dynamical grain load: 1-rotary arm; 2-disc of regulation of the advance angle arm; 3-movable keeper; 4-electromagnet.

The grain load tests were conducted within the speed interval from 6 to 26 m/s; the speed was changed at 2 m/s intervals. In order to determine the effect related with a vio-

lation of the grain internal structure at lower impact speeds (6-14 m/s) the bioyield point force tests were made. That force is equivalent to the coming-up of internal damage. The tests of the force mentioned were executed on a special station by compressing grains between two plain plates in the system set forth by Mohsenin [4].

So as to determine the impact limiting speed at which a complete destruction of the grain structure takes place under the effect of multiple loads, some grain load tests within the speed range 14-30 m/s, were carried out. The impacts were repeated till all the grains in a test sample were destroyed.

## RESULTS

Both an increase in the grain impact speed and repeating of those impacts reduce the grain strength. Such a tendency may be observed for both the winter and spring wheat varieties (Tables 1, 2, respectively). The force values at the bioyield point are higher for the winter varieties in comparison

Table 1. Significance of changes in the force at the bioyield point of grain in relation with impact speed and multiplication factor, evaluated via Student's distribution for two varieties of winter wheat

Impact speed (m/s)	Force at the bioyield point (N)				
	Load multiplication factor				
	1	5	10	15	20
	Almari				
6	68.5	69.4	61.1	66.2	64.4
8	68.7	64.4	65.7	62.8	63.0
10	70.6	70.8	65.1	51.6	47.5
12	64.1	65.2	63.5	48.5	48.6
14	65.3	62.6	56.3	49.6	40.4
	Gama				
6	80.2	83.5	75.6	78.9	72.6
8	86.2	80.9	79.8	75.5	76.9
10	79.8	75.2	73.6	65.1	63.7
12	72.2	73.6	64.9	62.3	58.3
14	70.0	65.1	65.2	57.6	52.2

**Table 2.** Significance of changes in the force at the grain bioyield point in relation with impact speed and multiplication factor, evaluated via Student's distribution for two varieties of spring wheat

Impact speed (m/s)	Force at the bioyield point (N)				
	Load multiplication factor				
	1	5	10	15	20
Jara					
6	65.2	66.4	61.4	58.5	58.9
8	63.7	65.5	68.9	61.0	60.0
10	60.7	60.4	62.1	58.8	50.2
12	59.4	52.9	45.3	40.1	36.5
14	62.6	50.7	42.3	42.2	38.9
Henika					
6	69.2	71.3	72.9	97.7	66.0
8	69.8	65.7	62.7	66.2	62.8
10	65.2	66.3	58.8	55.8	55.4
12	66.7	59.1	50.9	48.6	40.2
14	60.1	56.3	54.8	45.6	41.0

**Table 3.** Number of destroyed grain in relation with impact speed and multiplication factor for two varieties of winter wheat

Impact multiplication factor	Impact speed (m/s)						
	14	16	18	20	22	24	26
Almari							
10	0	9	64	76	86	100	100
20	1	32	23	19	12		
30	5	27	4	5			
40	10	9	2				
50	13	7					
60	13	8					
70	11	4					
80	16	1					
90	9	2					
100	6	2					
> 100	25						
Gama							
10	0	19	38	76	95	100	100
20	10	21	50	21	5		
30	24	13	10	2			
40	19	19	1	1			
50	16	17					
60	9	6					
70	9	6					
80	8		1				
90	1						
100	6						
> 100							

to the spring ones. From the statistical viewpoint, the effect of multiplication factor of the load (from 1 to 20) at the impact speed value of 6 m/s causes no significant decrease in the grain strength for the varieties tested. As well, insignificant differences in the grain strength were observed at the impact speed value of 8 m/s in two varieties, i.e., Almari and Henika. Actually, multiple loads with higher speeds appreciably reduce the grain strength. It may be thus assumed that for the wheat grain the multiple impact limiting speed bringing about grain internal defects without visible external symptoms amounts to 8 m/s. Striking grain at lower speeds does not affect significantly the grain internal structure. Grain impact tests at higher speeds repeated till grain destruction show that there appears a considerable diversification in the grain resistance to damage in the samples (Tables 3 and 4). At speed value of 14 m/s a part of grains is subject to destruction as early as after 20 impacts, whereas some of them keep up their external structure even after having exceeded 100 successive impacts. Among

the winter varieties subjects to impacts at 24 m/s all grains destroyed were ranged in the multiple factor class of 1-10. In the case of the spring wheat varieties that value amounts to 22 m/s (Table 4). At a big variability in the grain features, its destruction should be described statistically. Among a series of theoretical distributions the best conformity was attained by approximation of the data via Weibull distribution (Tables 5 and 6). Testing the multiple load effects is reasonable till the moment at which the figures can be approximated via the probability distribution. By assuming the aforementioned, it may be said that the limiting speed above which no conformity with Weibull distribution comes up amounts to 20 m/s in the case of winter and to 16 m/s for spring wheats.

**Table 4.** Number of destroyed grain in relation with impact speed and multiplication factor for two varieties of spring wheat

Impact multiplication factor	Impact speed (m/s)					
	14	16	18	20	22	24
	Jara					
10	0	0	72	96	100	100
20	22	13	19	3		
30	30	30	9	1		
40	23	12				
50	15	8				
60	4	3				
70	1	1				
80	9	0				
90	3	1				
100	3					
> 100	6					
	Henika					
10	0	0	68	94	100	100
20	5	9	26	4		
30	19	24	5	2		
40	23	31	1			
50	26	18	0			
60	7	13	0			
70	8	4	1			
80	5	1				
90	2					
100	3					
> 100	2					

**Table 5.** Values of the Weibull distribution parameters for the data obtained and the conformity test results  $\lambda$  for two varieties of winter wheat

Impact speed (m/s)	Almari			Gama		
	$\alpha$	$\beta$	$\alpha_\lambda$	$\alpha$	$\beta$	$\alpha_\lambda$
14	1.45	33.8	0.16*	1.65	32.9	0.05*
16	1.45	13.05	0.08*	1.58	15.04	0.24*
18	1.47	8.83	0.23*	1.5	8.8	0.46*
20	1.68	6.63	0.94*	1.96	5.39	0.05*
22	1.77	4.29	0.01	2.01	3.7	0.02
24	1.82	3.5	0.001	2.15	3.06	0.01
26	1.93	2.7	0.02	2.05	2.88	0.01

\* - conformity with Weibull distribution.

**Table 6.** Values of the Weibull distribution parameters for the data obtained and the conformity test results  $\lambda$  for two varieties of spring wheat

Impact speed (m/s)	Jara			Henika		
	$\alpha$	$\beta$	$\alpha_\lambda$	$\alpha$	$\beta$	$\alpha_\lambda$
14	1.21	15.6	0.16*	1.83	36.9	0.05*
16	1.61	12.0	0.08*	1.52	24.0	0.24*
18	1.57	5.83	0.03*	1.8	9.9	0.06*
20	1.68	6.03	0.04*	1.98	6.3	0.005*
22	1.72	5.48	0.21	2.01	4.90	0.32

\* - conformity with Weibull distribution.

These values determine the upper impact speed limit while conducting tests on the grain multiple load effects.

#### CONCLUSIONS

1. The multiple impact limiting speed at which a violation of the grain internal structure appears but without significant external damages, amounts to 8 m/s.

2. The multiple impact upper speed value at which destruction of the grain external structure comes up, amounts to 20 m/s for winter and to 16 m/s for spring wheats.

3. Winter wheat is more resistant to multiple, dynamical loads than spring wheat.

#### REFERENCES

1. Byszewski W., Haman J.: *Gleba, Maszyna, Roślina*. PWN, Warsaw, 1977.
2. Gaska R., Kolowca J., Ślipek Z.: Wpływ obciążeń mechanicznych na wartość biologiczną ziarna pszenicy. *Rocz. Nauk Roln.*, 73-C-4, 17-24, 1978.
3. Grundas S., Szot B.: Biological effects of static loading of wheat grain in mass. *Zesz. Probl. Post. Nauk Roln.*, 203, 515-520, 1978.
4. Mohsenin N.N.: *Physical Properties of Plant and Animal Materials*. Gordon and Breach Science Publishers, New York, 1970.