

INVESTIGATIONS OF THE INFLUENCE OF COMPONENT CHARACTERISTICS OF A COAT ON THE GERMINATION ABILITY OF COATED SEEDS

W. Korpál

Department of Technology and Apparati for Chemical and Food Industry, Technical - Agricultural University, Seminaryjna 3, 85-326 Bydgoszcz, Poland

Accepted July 9, 1999

A b s t r a c t. This work reports the influence of the hygroscopic characteristics of a coat composed of various ingredients, its relative mass in proportion to the seed and the base moisture on the germination ability of the Jawa carrot coated seeds. It is shown that all the parameters strongly affect the quality of the coated seeds and that proper coating can significantly improve their germination capability.

K e y w o r d s: seed-coating, seed-pelleting, application-methods

INTRODUCTION

The quality of coated seeds of industrial plants, vegetables and flowers significantly depends on the composition of particular ingredients of the coat, their characteristics and mass. The coat consists mainly of a substance further called the basic mass which is basically used to increase the seed volume. Other components such as fungicides, insecticides and nutritive ingredients are also important and their amount and distances from the surface of the coated seeds may be crucial. However, because the purpose of this work was to describe the influence of component characteristics of the coat basic mass on the germination ability of the coated seeds, this problem was practically neglected. The basic mass should be relatively cheap, easily available, air-permeable, sorptive (to diminish damaging effect of the high salt concentrations) and have the capability of water absorption adequate for every kind of seed. For

production of the basic mass the following products were most often used [5,7,8]:

- peat, compost, mixture of turf with distributed manure, mixture of peat and manure;
- clay, spar, kaolin, silt, volcanic ash, carbon black, bentonit etc.;
- wooden dust, cellulignine, etc.

In several cases an improper coat composition diminishes the sowing quality of the seeds while a correct composition can significantly improve it. Studies by the present author show, that one of the fundamental characteristics of the basic mass components is their moisture absorptivity [7]. It usually affects germination ability of the seeds very strongly. The coat components should be selected by taking into account also unfavourable moisturing conditions of soil during germination. In this work the influence of the agents mentioned above and the ratio of the coat mass to the seed mass on the sowing quality of the coated seeds (mostly various kinds of vegetables) was investigated.

MATERIALS

The seeds of the Jawa carrot with comparatively low germination ability (60%) were used in order to show the influence of individual parameters on the quality of the coated seeds. The basic mass of the coats consisted of a mixture of

kaolin-spar in the weight ratio of 1:2 and peat. By changing the proportion of the kaolin-spar and peat mixture, of kaolin-spar the different water absorptivity of the coat was obtained. Individual components were used in the dust form with the known seed distribution, measured with the laser equipment "Analysette 22" produced by Fritsch. The 10% water solution of the yellow dextrin was used as a granular liquid. In all the samples the fungicides were added to the seeds in the same weight ratio (Funaben T, Apron SD, Ronilan), whereas during the coating process the insecticide (Marschal 25 ST) was added to the coat. Adding and coating took place in the installation shown in Fig. 1.

After coating, the seeds were dried in the temperature not higher than 40°C and calibrated in the screen through the sieve system with sieve mesh diameters of 2.0, 2.5, 3.0, 4.0 and 5.0 mm.

Germination ability of the seeds was tested according to Belotti [3], Domaradzki [4], Polish Standard [6] with accordion pleated oil absorbent paper saturated with water by 50, 60, 70, 80, 90, and 100%.

Water absorptivity of the coated seeds was tested applying two methods: static and dynamic [1,2,7]. The scheme of the apparatus for testing water absorptivity is shown in Fig. 2. Additionally, for every sample of the coated seeds the ratio of the coat mass to the seed mass was measured.

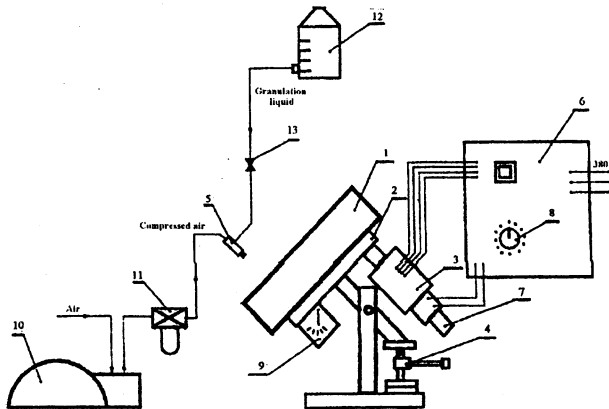

Fig. 1. Configuration of installation for adding and coating seeds: 1 - granular plate, 2 - plate base, 3 - granulator drive, 4 - screw elevator, 5 - pneumatic atomizer, 6 - steering cubicle, 7 - rate generator, 8 - handwheel of rotating frequency change of plate, 9 - protractor, 10 - compressor, 11 - reductor, 12 - container of granular liquid, 13 - regulating valve of granular liquid.

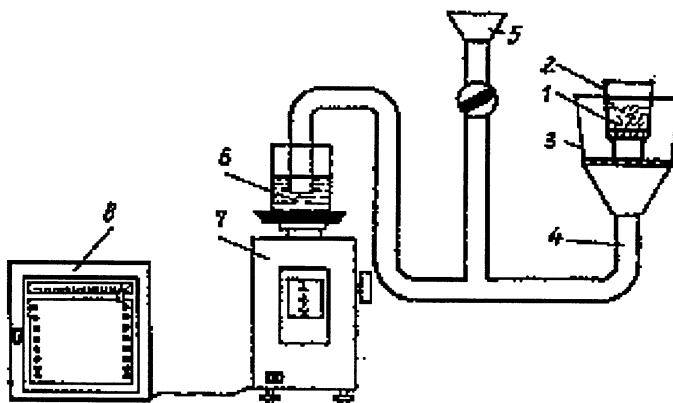

Fig. 2. Scheme of apparatus for testing water absorptivity: 1 - tested sample, 2 - vessel with porous bottom, 3 - small funnel, 4 - connecting pipes, 5 - funnel, 6 - vessel with water, 7 - scale, 8 - computer.

RESULTS

The results obtained are shown in Table 1. Every sample contained a different composition of the basic mass in which the ratio of spar to kaolin remained constant and only peat proportion was changed.

The water absorptivity of the coats shown in Table 1 depended directly on the composition of the coat basic mass. Here, the parameter k describes the ratio of the coat mass to the raw seed mass. Investigation of the germination capability of the individual samples of the coa-

ted seeds was carried out for the moisture of the base (the oil absorbent paper) 50-100%.

DISCUSSION

The influence of the germination ability of the investigated coated seeds on the base moisture with various compositions of the basic mass in the coat and the constant ratio of the coat mass to the seed mass is shown in Fig. 3. For the individual types of coat characterised by a certain water absorptivity, germination capability of the seeds depended significantly

Table 1. Results of investigations of Jawa carrot coated seeds

Number of seed sample	Germination ability of seeds ZK, with base moisture X (%)						Water absorptivity of coat Φ (%)	k
	50	60	70	80	90	100		
1	2	3	4	5	6	7	8	9
1	77	69	67	80	76	71	50.75	6.07
2	71	69	66	72	71	70	67.51	5.79
3	74	78	72	71	82	83	78.15	6.64
4	62	67	65	55	59	64	86.03	6.05
5	51	65	59	55	56	61	100.09	6.44
6	58	69	55	60	62	52	101.09	6.53
7	49	55	66	52	49	55	114.36	6.12
8	51	59	55	59	52	52	130.07	6.38
9	59	64	64	59	62	52	48.45	10.71
10	55	63	63	62	56	45	70.13	10.33
11	61	56	54	50	46	55	78.90	11.45
12	52	52	51	42	41	48	89.15	11.51
13	53	46	53	48	45	40	96.64	10.70
14	45	40	40	39	46	35	101.94	10.93
15	55	46	39	40	42	34	107.13	11.65
16	52	47	43	44	42	37	134.37	11.50
17	45	51	39	36	27	35	157.13	11.90
18	55	54	55	40	52	48	47.80	17.16
19	46	41	45	43	39	35	69.44	16.28
20	30	45	38	37	39	29	74.69	19.11
21	35	33	37	26	31	37	89.11	16.51
22	42	31	35	36	38	27	97.60	14.58
23	40	33	22	34	31	29	106.11	14.95
24	35	22	22	16	22	23	108.76	17.15
25	34	28	29	21	15	24	124.76	19.85
26	35	41	28	30	15	17	168.23	21.65
27	54	56	46	47	43	46	44.50	22.92
28	44	29	34	32	30	35	67.21	21.23
29	17	15	23	18	16	20	75.64	29.17
30	27	18	27	18	18	22	87.15	22.68
31	31	20	25	28	18	30	96.18	21.92
32	29	17	9	22	15	14	106.25	18.90
33	25	15	12	14	16	15	138.70	25.11
34	18	9	13	7	2	11	129.12	40.04
35	4	5	4	3	1	1	133.42	75.78

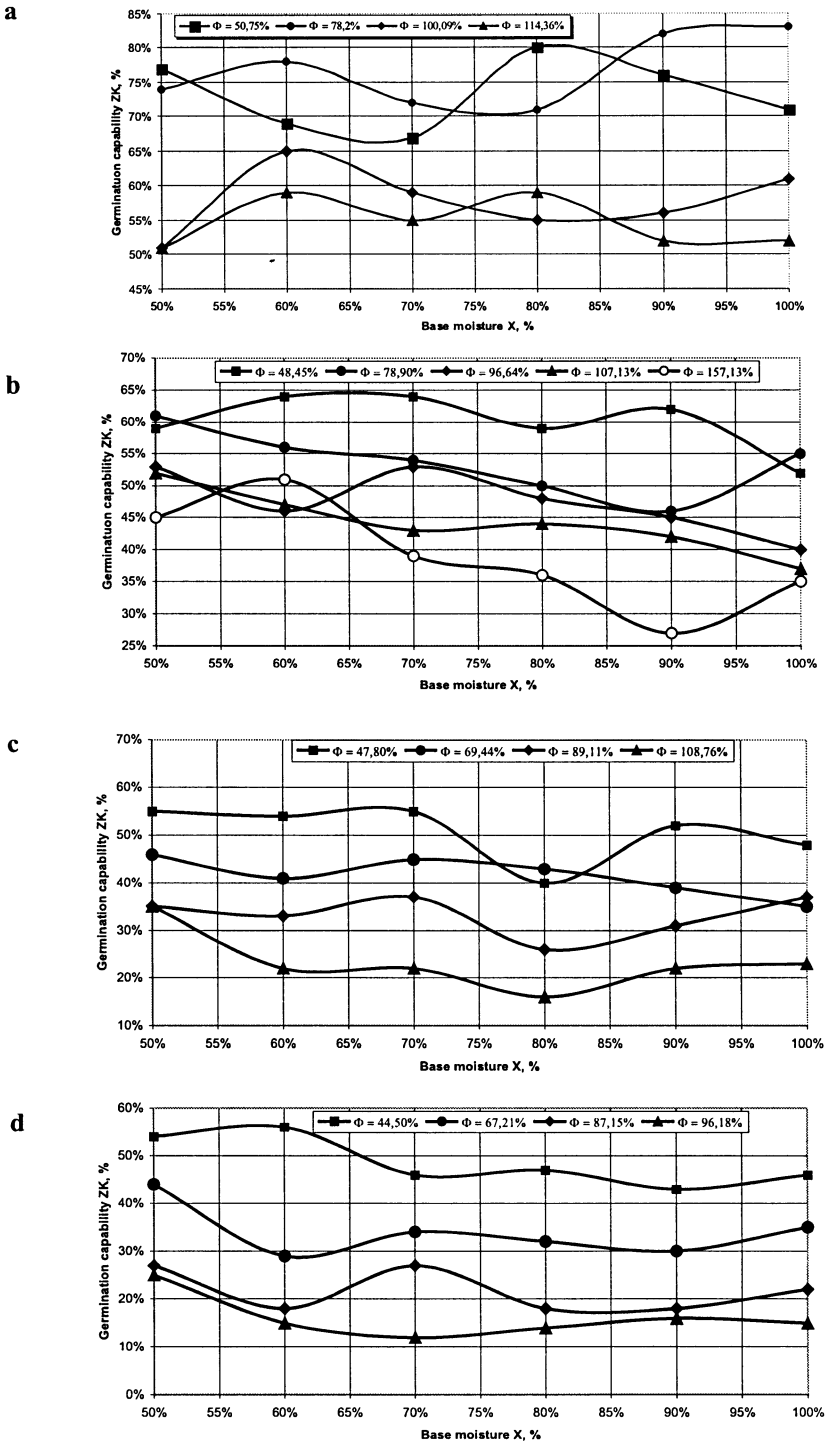

Fig. 3. Influence of germination ability of seeds on the base moisture for various compositions of coat basic mass and k which is equal to: a) 6.25, b) 11.2, c) 16.8, and d) 23.0.

on the base moisture. The values of the base moisture for which the seeds achieve the highest germination capabilities are unstable and depend on the water absorptivity of the coats and the ratio k . Analysis of the curves in Fig. 3 indicates that high values of the coat water absorptivity as well as an increase of the coat mass in comparison to the seed mass affect germination capability of the coated seeds unfavourably.

Figure 4 shows an example of the influence of germination capability of the investigated seeds on the coat water absorptivity for various k values (the ratio of the coat mass to the seed mass) and the base moisture 60%. Here, an increase of the coat water absorptivity, and therefore an

increase of the fraction of more hygroscopic substance in the coat base mass is followed by very strong decrease of the germination capability in the Jawa carrot coated seeds.

Similar dependence can be observed for different investigated moisture levels of germinating bases. The quality of the Jawa carrot coated seeds is also affected by the ratio of the coat mass to the seed mass (Fig. 5). Growth of the coat mass in proportion to the seed mass significantly reduces germination capability. This relation is observed for all the hygroscopic conditions of the germinating base.

Decrease of the germination ability as a result of growing coat hygroscopicity is also observed, as has been mentioned earlier.

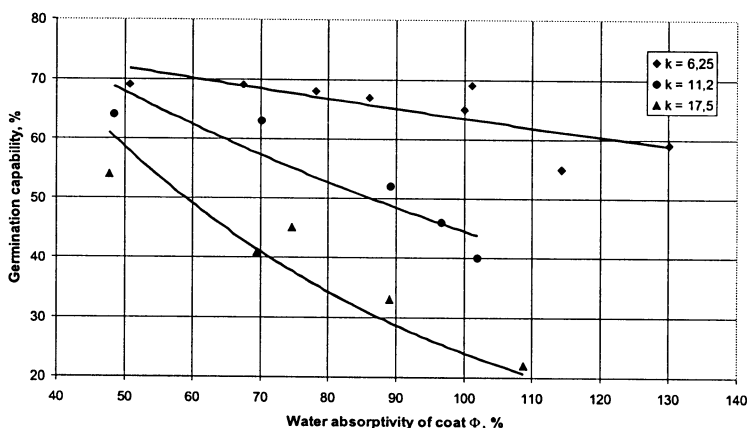

Fig. 4. Influence of germination ability of coated seeds on the coat water absorptivity for base moisture $X = 60\%$ and various values of k .

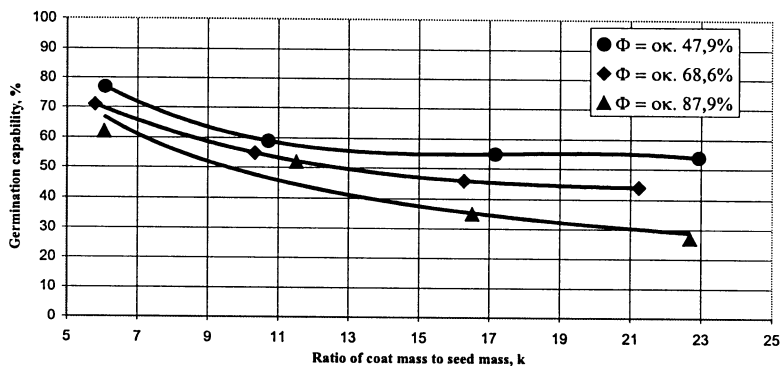

Fig. 5. Influence of the ratio of coat mass to seed mass on germination ability ($X = 50\%$).

CONCLUSIONS

This work reports the influence of the base mass composition in the coats, their hygroscopic characteristics described by the moisture absorptivity, the ratio of the coat mass to the seed mass and the moisture of the germinating base on the quality of the Jawa carrot coated seeds. The obtained results lead to the following conclusions:

1. The coated seed quality characterised by the germination capability value depends on the hygroscopic characteristics of components in the coat. For the coat components like clay, silt, peat etc., changing composition towards components with higher hygroscopicity causes decrease of the seed germination capability.

2. An increase in the coat size (described in this work as the ratio of the coat mass to the seed mass) unfavourably affects the germination capability.

3. The coat composition and its mass strongly affect the seed germination ability in various moisture condition of the base during germination. In the investigated range of the base moisture 50-100% the differences in the seed

germination were significant (even up to 10%).

4. The quality of the Jawa carrot seeds can be improved by their coating with the proper base mass and by proper moisture conditions during germination. In this work the germination ability of the coated seeds was up to 83%, whereas for the non-coated seeds it was only 60%.

REFERENCES

1. **Aksielrud G.A., Altszuler M.A.:** Movement of mass in porous corpses (in Polish). WNT, Warsaw, 1987.
2. **Andrzejewski R., Gutowski W.:** Physical properties of dusts (in Polish). Publishers "Śląsk", Katowice, Poland, 1968.
3. **Belotti J.:** Methodical indications for evaluation of coated seeds (in Polish). BIHiAR, 5/6, 1973.
4. **Domoradzki M.:** Determination of germination capability of coated seeds. Int. Agrophysics, 13, 431-433, 1999.
5. **Muchin W.:** Coating of Seeds (in Polish). PWRiL, Warsaw, 1974.
6. Polish Standard: PN-94/R 65950, 1994.
7. **Szorc J., Korpala W., Weiner W., Ringel T.:** Studies on moisture absorption by materials used for seed coating (in Polish). Zesz. Probl. Post. Nauk Roln., 425, 249-256, 1996.
8. **Tonkin H.J.B.:** Pelleting and other pre-sowing treatments. Advances in Research and Technology of Seeds, 4, 84-105, 1979.