

Biogas as Resources of Energy

S. Yimer, O. P. Sahu*

Department of Chemical Engineering, KIOT, Wollo University, PO Box 1145, Dessie, Ethiopia
Tel: +251933520653

*E-mail address: ops0121@gmail.com

ABSTRACT

The objective of the study described the importance of biogas and its importance. The biogas generally obtained from the waste. The so-called wastes that we discard and suffer with the consequences of improper management are of course partly huge energy and fertilizer sources that can support energy demands of cities greatly. Urban waste disposal is a serious challenge in all cities in the developing world, and its accumulation is an additional health hazard. Reliable and generally accepted disposal of the comparatively large amounts of digestate produced is necessary if biogas production is to be implemented. In this regard's discussion has been about the biogas production reaction involves, design and applications

Keyword: Composter; Digestor; Energy; Fuel; Methane

1. INTRODUCTION

Due to scarcity of petroleum and coal it threatens supply of fuel throughout the world also problem of their combustion leads to research in different corners to get access the new sources of energy, like renewable energy resources. Solar energy, wind energy, different thermal and hydro sources of energy, biogas are all renewable energy resources. But, biogas is distinct from other renewable energies because of its characteristics of using, controlling and collecting organic wastes and at the same time producing fertilizer and water for use in agricultural irrigation (Memon. et al., 2012). Biogas does not have any geographical limitations nor does it require advanced technology for producing energy, also it is very simple to use and apply. Deforestation is a very big problem in developing countries like India, most of the part depends on charcoal and fuel-wood for fuel supply which requires cutting of forest (Regassa, et al., 2011). Also, due to deforestation It leads to decrease the fertility of land by soil erosion. Use of dung, firewood as energy is also harmful for the health of the masses due to the smoke arising from them causing air pollution. We need an ecofriendly substitute for energy (Fisher, et al., 1983).

Biogas typically refers to a gas produced by breakdown of organic matter in the absence of oxygen. Organic waste such as dead plant and animal material, animal feces, and kitchen waste can be converted into a gaseous fuel called biogas (Gelegenis, et al., 2007).

Biogas originates from biogenic material and is a type of bio fuel. Biogas is produced by the anaerobic digestion or fermentation of biodegradable materials such as biomass, manure, sewage, municipal waste, green waste, plant material, and crops (Kacprzak, et al., 2010). Biogas comprises primarily methane (CH₄) and carbon dioxide (CO₂) and may have small amounts of hydrogen sulphide (H₂S). The composition of biogas is shown in Table 1.

Table 1. Composition of the biogas.

S.No	Component	Symbol	Concentration
1	Methane	CH ₄	55-65 %
2	Carbon dioxide	CO ₂	30-40 %
3	Water	H ₂ O	2-7 %
4	Hydrogen sulphide	H ₂ S	2-3 %
5	Ammonia	NH ₃	0-0.05 %
6	Nitrogen	N	0-2 %
7	Oxygen	O	0-2 %
8	Hydrogen	H	0-1 %

Composition of biogas depends upon feed material also. Biogas is about 20 % lighter than air has an ignition temperature in range of 650 to 750 °C (Kushwaha, et al., 2010). An odorless and colorless gas that burns with blue flames similar to LPG gas. Its caloric value is 20 Mega Joules (MJ) / m³ and it usually burns with 60 % efficiency in a conventional biogas stove. This gas is useful as fuel to substitute firewood, cow-dung, petrol, LPG, diesel, & electricity, depending on the nature of the task, and local supply conditions and constraints (Rajeshwari, et al., 2000).

Biogas digester systems provides a residue organic waste, after its anaerobic digestion (AD) that has superior nutrient qualities over normal organic fertilizer, as it is in the form of ammonia and can be used as manure (Spece, 1990). Anaerobic biogas digesters also function as waste disposal systems, particularly for human wastes, and can, therefore, prevent potential sources of environmental contamination and the spread of pathogens and disease causing bacteria. Biogas technology is particularly valuable in agricultural residual treatment of animal excreta and industrial refuse (residuals). The recovered gas is 60-80 percent methane, with a heating value of approximately 600-800 Btu/ft³. Gas of this quality can be used to generate electricity; it may be used as fuel for a boiler, space heater, or refrigeration equipment; or it may be directly combusted as a cooking and lighting fuel (Demirel, et al., 2005).

2. BIOGAS PRODUCTION

Organic substances exist in wide variety from living beings to dead organisms. Organic matters are composed of Carbon (C), combined with elements such as Hydrogen (H), Oxygen (O), Nitrogen (N), and Sulphur (S) to form variety of organic compounds such as

carbohydrates, proteins & lipids. In nature MOs (microorganisms), through digestion process breaks the complex carbon into smaller substances (Gally, 1996).

2. 1. Types of reaction

Generally the production of biogas divided into two way:

(1). Aerobic: The digestion process occurring in *presence of Oxygen* is called **Aerobic digestion** and produces mixtures of gases having carbon dioxide (CO₂), one of the main “green houses” responsible for global warming (Waldrop and Firestone, 2004).

(2) Anaerobic: The digestion process occurring *without (absence) oxygen* is called **anaerobic digestion** which generates mixtures of gases (Six et al., 2006).

Reaction occurs in anaerobic digester:

Hydrolysis: In the first step the organic matter is enzymolysed externally by extracellular enzymes, cellulose, amylase, protease & lipase, of microorganisms. Bacteria decompose long chains of complex carbohydrates, proteins, & lipids into small chains. For example, Polysaccharides are converted into monosaccharide. Proteins are split into peptides and amino acids (Belloso and Fortuny, 2011).

Acidification: Acid-producing bacteria, involved this step, convert the intermediates of fermenting bacteria into acetic acid, hydrogen and carbon dioxide. These bacteria are anaerobic and can grow under acidic conditions. To produce acetic acid, they need oxygen and carbon. For this, they use dissolved O₂ or bounded-oxygen. Hereby, the acid-producing bacteria create anaerobic condition which is essential for the methane producing microorganisms (Cristiani-Urbani, et al., 2000). Also, they reduce the compounds with low molecular weights into alcohols, organic acids, amino acids, carbon dioxide, hydrogen sulphide and traces of methane. From a chemical point, this process is partially endergonic (i.e. only possible with energy input), since bacteria alone are not capable of sustaining that type of reaction.

Methanogenesis: (Methane formation) Methane-producing bacteria, which were involved in the third step, decompose compounds having low molecular weight. They utilize hydrogen, carbon dioxide and acetic acid to form methane and carbon dioxide (Rao and Singh, 2004). Under natural conditions, CH₄ producing microorganisms occur to the extent that anaerobic conditions are provided, e.g. under water (for example in marine sediments), and in marshes. They are basically anaerobic and very sensitive to environmental changes, if any occurs. The methanogenic bacteria belong to the archaeobacter genus, i.e. to a group of bacteria with heterogeneous morphology and lot of common biochemical and molecular-biological properties that distinguishes them from other bacterias. The main difference lies in the makeup of the bacteria's cell walls (Yadvika, et al., 2004).

2. 2. Design Parameters

The reactor dimensions and biogas potential depends on:

- The type of substrates to be digested
- The quantity of each in metric tons per year
- The total solid content in percentage
- Total solids content (TS) = 100 (%) - water content (%)

- The organic content in percentage: Organic dry matter content is determined by incinerating the dried sample at 550 °C for six hours and weighing the remaining ashes.
- $Organic\ content\ (ODM) = (mass\ of\ TS(g) - mass\ of\ ashes\ (g) \times 100 / mass\ of\ TS(g)$
- The size of the digester (V_d) is determined by the retention time (RT) and the daily substrate input in m^3 (S_d).
- The following formula can be used in order to calculate the appropriate volume:
 $V_d = S_d \times RT$

Several different systems have been designed for anaerobic digestion. Following are basic descriptions of the more popular systems used on farms.

A. Plug Flow System

The plug flow system usually takes the form of a long concrete tank with a slight grade over the length. Influent is either continuously or intermittently added to one end and flows by gravity to the opposite end. The contents are not mixed mechanically. The retention time is thus a function of channel length, channel grade, and the loading rate. The plug flow digester is best suited for manure with a higher solids content (11 to 13% total solids) such as that of a dairy operation (Agstar, 2004). Figure 1 shows the main elements of a plug flow digester system.

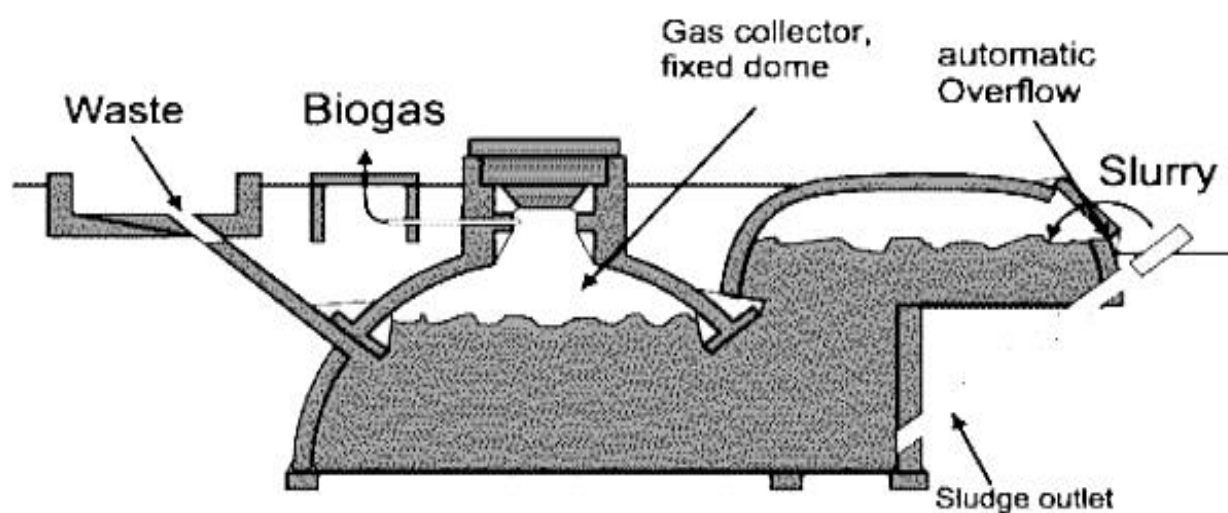

Figure 1. Typical plug flow digester system.

B. Complete Mixed System

Also known as a Completely Stirred Tank Reactor (CSTR), the complete mixed system is most commonly a circular tank with a mechanical agitator, which is shown in Figure 2. The mixing prevents settling and maintains contact between bacteria and the manure. It also helps maintain a uniform temperature (Barker, 2001). Electricity input costs are higher due to the intermittent mixing of the digester. However, the mixing can cause foaming in the tank, which is undesirable because it occupies digester volume and can clog gas lines. Complete mix systems are able to handle the widest range of solids concentrations (3 to 10 % total solids) (Agstar, 2004). Influent is often added to the digester as effluent is excreted in small

quantities at regular intervals. Therefore the retention period of manure in a complete mix digester is not necessarily uniform.

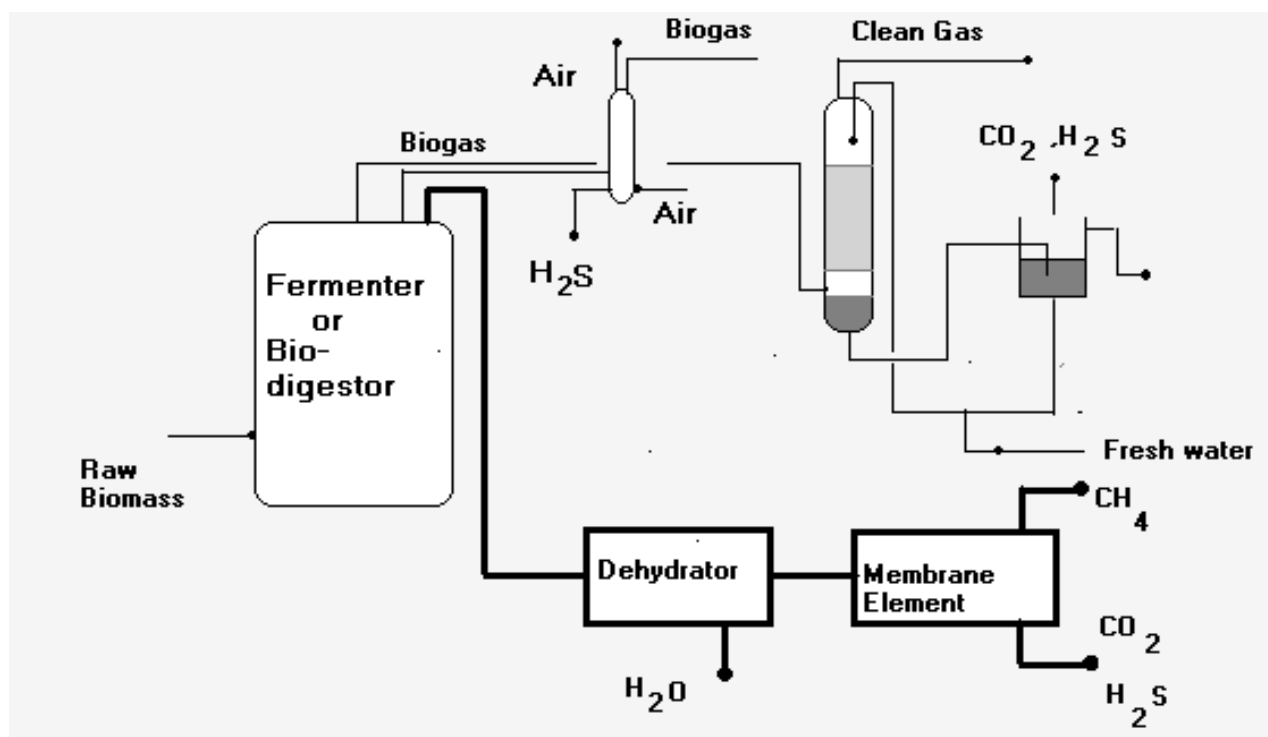

Figure 2. Complete mixed digester system.

3. FACTOR AFFECTING THE PRODUCTION OF BIOGAS

Following is a discussion of the most important parameters which must be considered in the design of an anaerobic digestion system:

3. 1. Temperature

Three ranges exist for anaerobic digestion:

- Psychrophilic range - Between 5 °C and 25 °C; characterized by slower methane production and longer retention times.
- Mesophilic range - Between 30 °C and 40 °C; the most widely used of the three (Poulsen, 2003), this range balances heating costs with methane production.
- Thermophilic range – From 50 °C to 60 °C; produces the most methane but is also the most sensitive, due to fewer bacterial species in existence.

Once a stable temperature is reached, fluctuations should be kept within 5 °C to avoid killing the desired bacteria (Pos, et al, 1981). Thermophilic tolerance is generally less than that of lower temperatures (Price and Cheremisinoff, 1981). Each temperature range at which the digester can be operated has its own advantages.

The thermophilic process has been found to be superior to the mesophilic process from an energy balance and, thus, “profit” point of view (Ahring, 1994).

Thermophilic digesters usually achieve better degradation of long-chain fatty acids, have a shorter retention time, and require less biomass compared to the quantity of methane produced.

The thermophilic process also achieves higher pathogen and weed seed destruction than the mesophilic process alone (El-Mashad, et al, 2004). However, the risk of ammonia inhibition is greater and more energy is required to operate a thermophilic digester (Poulsen, 2003). Thermophilic processes are considered to be more prone to instability than mesophilic due to fluctuations in input quality (Earth Tech, 2002; El-Mashad, et al, 2004).

However, in a study of major centralized biogas plants in Denmark, Ahring (1994) found no significant difference in volatile fatty acid concentrations between the two processes. Ahring (1994) conceded that the start-up time of thermophilic digesters is longer than that of a mesophilic reactor due to the low numbers of thermophilic bacteria in organic waste. Most of the agricultural digesters in the United States are mesophilic (Kramer, 2002). The process is slightly more stable and adaptable to fluctuations in feedstock quality than thermophilic (Earth Tech, 2002). The lower heating requirements of mesophilic temperatures translate into lower costs. Residence time should be at least 15 days for adequate digestion (Earth Tech, 2002).

Psychrophilic digesters require a solids retention time approximately twice as long as mesophilic (Price and Cheremisinoff, 1981). These digesters require the least amount of energy input. Biogas production is slow but gas quality and other parameters indicate favorable process stability. These systems are commonly found in the form of a covered lagoon and, as such, they are usually subject to fluctuations in temperature.

3. 2. Loading Rate

This is expressed as the weight of volatile solids (VS) per unit of volume of digester capacity per unit of time. Loading rates typically range from 1.2 to 11.0 kg VS/m³/d for various types of digesters and manure sources (Persson et al, 1979). While high loading rates use the digester volume more efficiently, they also increase solids concentration, retention time and alkalinity, which must be taken into consideration.

3. 3. Retention Time

The Hydraulic Retention Time (HRT) and Solids Retention Time (SRT) are the average lengths of time the liquid or solid portion of manure remains in the digester. Generally, the lower the operating temperature (e.g. psychrophilic digestion) the higher the retention time that is needed.

3. 4. Solids Concentration

Normally reported as the percentage dry matter and the volatile solid percentage of that dry matter, the solids concentration is necessary to determine the loading rate. The solids concentration also helps to determine the most suitable type of digester.

3. 5. Alkalinity and pH

Optimum pH conditions for methanogenic bacteria range from 6.4 to 7.6 (Price and Cheremisinoff, 1981). Other bacterial species are more tolerant to pH levels outside of this range.

4. APPLICATION OF BIOGAS

There are many uses for the gas produced by anaerobic digestion. Biogas can be substituted for any application designed for natural gas. A boiler will convert the methane to heat. Micro-turbines, gas turbines, internal combustion engines and fuel cells convert biogas into both electricity and heat. A gas flare is used to dispose of gas when levels are too low to warrant a heat or electricity generation system.

4. 1. Microturbine

Microturbines are based on the principles of large gas turbines. They include an improvement that contributes to an improved electrical efficiency - a heat exchanger attached to the exhaust. The recovered thermal energy pre-heats the inlet air, which is mixed with biogas. The air/gas mixture is burned and allowed to expand through a turbine section to perform work. A gearbox and other moving parts are replaced by inverter-based electronics allowing the turbine to be operated at high speeds. The shaft can rotate as fast as 96,000 rpm. The exhaust gas is directed to the heat exchanger and then can be piped to a second heat recovery unit for further heat recovery. Biogas must be compressed to approximately 585 kPa (85 psi) before use in a microturbine (Wiltsee and Emerson, 2004). The flow diagram of microturbine is shown in Figure 3.

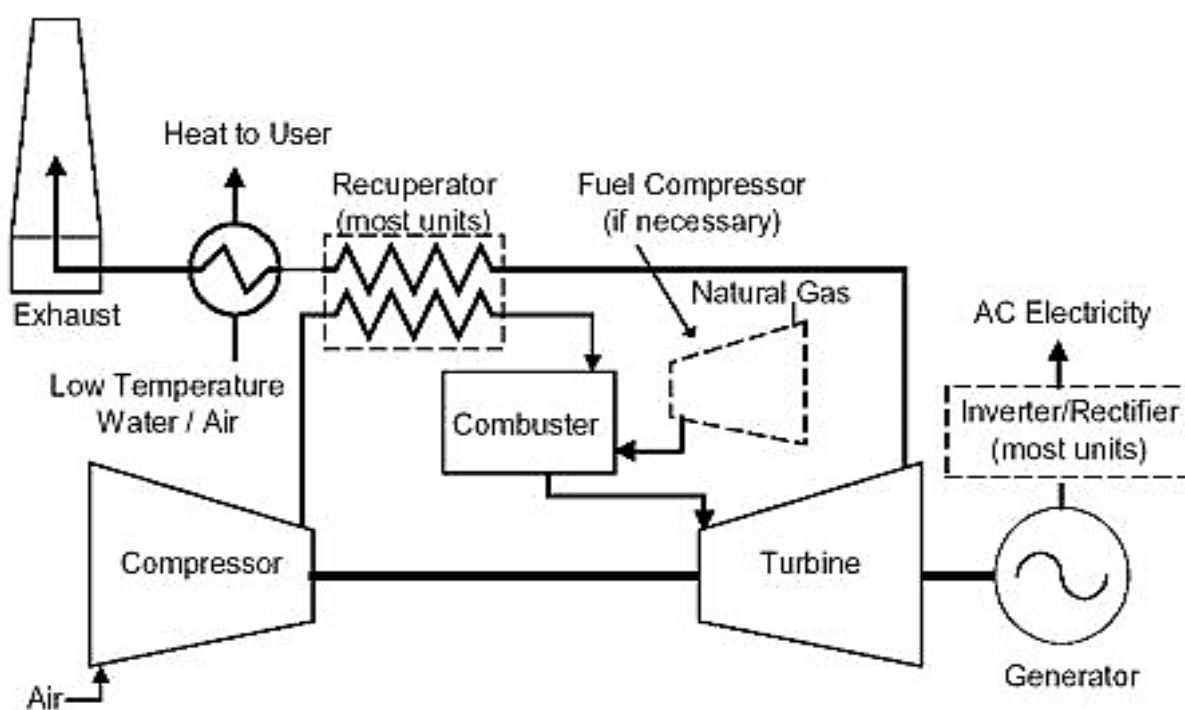

Figure 3. Micro-gas-turbine for electricity generation.

The compressor may be included as a component of the microturbine system or may be run independently. Hydrogen sulfide does not need to be removed from the biogas. There are models of microturbines that are able to handle H₂S levels as high as 7 %, much higher than

any gas produced by an agricultural anaerobic digester (Capstone, 2005). Other models are equipped with a fuel conditioner 'on-board' (Ingersoll-Rand, 2003). Water vapour can contain compounds that may harm the fuel injectors, fuel control valves or the compressor. Thus, the vapour must be removed from the biogas. This represents the biggest concern. It is important to note that microturbines may be easily switched to run on natural gas in periods of low biogas production. Compared to internal combustion engines, microturbines have a much lighter maintenance schedule. A continuously running microturbine requires as little as 24 hours of maintenance for every 8000 hours of operation (Wiltsee and Emerson, 2004). Due to the smaller number of moving parts, a microturbine produces relatively low levels of noise and vibration. Therefore, a heavy foundation is not required (Brandon, 2002).

Microturbines are capable of achieving electrical efficiencies of 25 to 30 %. Increasing ambient air temperature and increasing altitude have a detrimental effect on the efficiency of microturbines, by decreasing the density of the air (NRC, 2002). Also, a large portion of the electrical efficiency comes from the inlet air/exhaust heat exchanger. This means the microturbine will need a warm-up period in order to maximize its potential efficiencies. The exhaust gas from the first heat exchange unit can be 230 to 315 °C, depending on the model, ambient environment, and altitude (Wiltsee and Emerson, 2004). These secondary heat exchange units have been reported to reach thermal efficiencies of 45 % (Willingham and Pipattanasomporn, 2003). It is important to note that all thermal energy available for recovery is in the form of the microturbine exhaust. This exhaust gas stream is concentrated and is hot enough to be used directly (e.g. in greenhouses or drying applications) (Anon, 2005b). Emission levels of NO_x from a microturbine can be less than 9 ppm (NRC, 2002).

4. 2. Fuel cells

Fuel cells convert chemical energy to electricity without combustion. This conversion is similar to that of a battery. There are three sections to a fuel cell:

- **Fuel pre-treatment and processing section** – Here, the gas is purged of H₂S and other harmful contaminants. The processing section includes a fuel reformer that converts methane to a hydrogen-rich gas used by the fuel cell stack.
- **Fuel cell stack** - The electricity-producing chemical reaction takes place here.
- **DC to AC power electrical conditioning and controller section** - This section converts the DC electricity produced by the fuel cell to grid-standard AC electricity.

There are several different types of fuel cells. Each is named for the type of electrolyte used.

- **Alkaline Fuel Cell** – These are the oldest fuel cell types. They were originally used in space shuttles. These fuel cells are easily contaminated by carbon, therefore their application on earth is limited (Anon, 2005).
- **Phosphoric Acid Fuel Cell** – This type was the first commercially available fuel cell, in 1992. They operate at a temperature between 150 and 220 °C (Anon, 2005). They are reliable sources of energy, with an electrical efficiency of between 36 and 40%. These efficiencies, however, lag behind other fuel cells. Furthermore, the price has not decreased as expected and at least one fuel cell manufacturer is phasing out of this type of fuel cell in favour of the proton exchange membrane (NSTAR, 2005).
- **Proton Exchange Membrane (PEM) Fuel Cell** – These are the leading candidates for use in an automobile as they are capable of starting quickly and match a changing load. This ability to start quickly stems from a relatively low operating temperature of

90 °C (Anon, 2005). Most stationary PEM fuel cells will have a capacity under 10 kW (NSTAR, 2005). A PEM fuel cell has become the first fuel cell to generate electricity from agricultural biogas. The 5 kW unit is being run intermittently by researchers from the University of Minnesota on a dairy farm (Anon, 2005).

- **Solid Oxide Fuel Cell (SOFC) and Molten Carbonate Fuel Cell (MCFC)** – Both of these fuel cells operate at very high temperatures. MCFC operate between 600 and 700 °C, while SOFC function between 650 and 1000 °C. This high operating temperature translates into high quality exhaust heat, but also a slower start-up time. MCFC range in size from 250 kW to 3 MW units. SOFC are being developed in the 5 kW to multi-megawatt range. The “Fuel to Electricity” efficiencies of both MCFC and SOFC approach 60 % (Anon, 2005).

Biogas intended for use in a fuel cell must first be purified. The catalysts of fuel cells cannot tolerate hydrogen sulfide (Minott et al., 2004). Levels higher than 0.5 to 1.0 ppm are unacceptable for a high temperature fuel cell generator. Water vapour and carbon dioxide are considered fuel diluents. The purified biogas would not need to be further compressed. Methane can be used in the range of 1 to 3.5 kPa (0.14 to 0.5 psi) for a phosphoric acid fuel cell. Since fuel cells are an emerging technology, their maintenance is likely to be time-consuming and expensive.

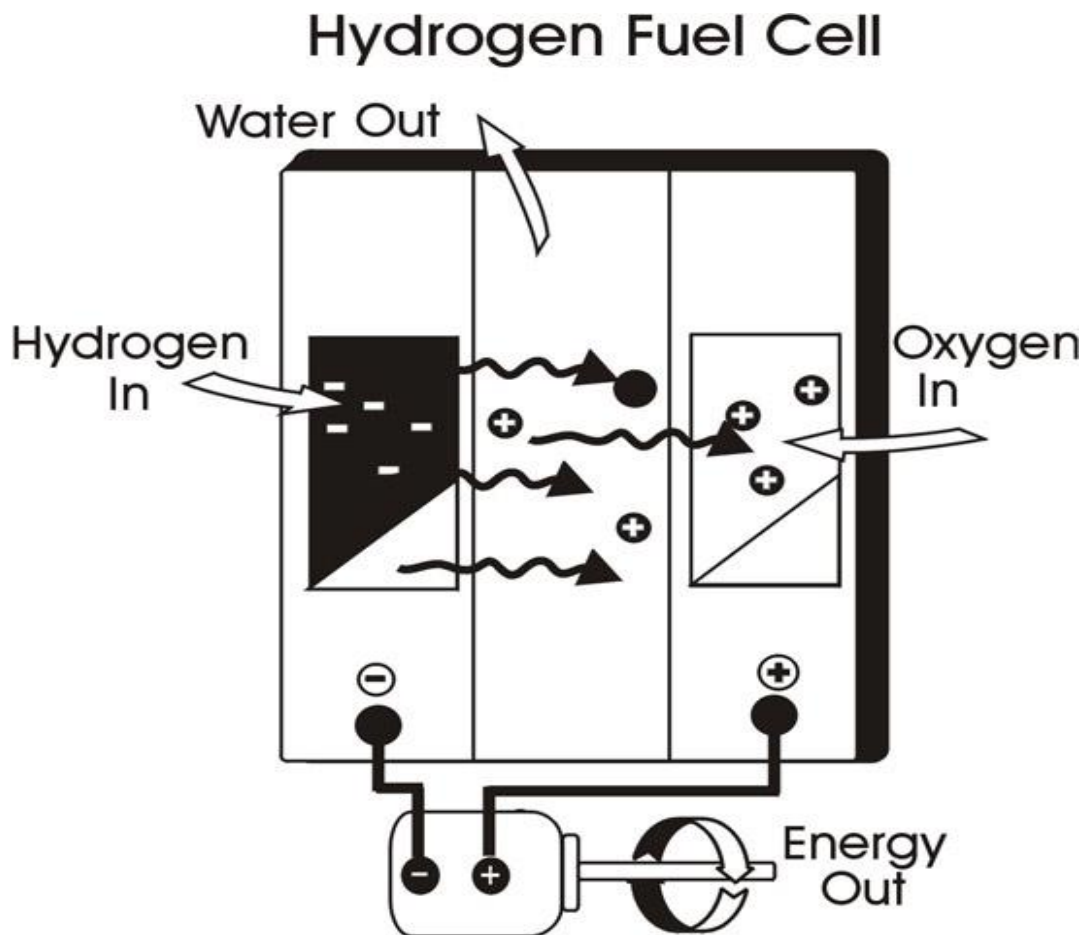

Figure 4. Fuel cell set up.

Fuel cells require specialized engineering, plumbing, catalyst, and thermal and electrical power generation expertise that is probably only available from the manufacturer (Minott, et al., 2004). Noise is generally not an issue since there is no combustion and any forms of sound are produced by water pumps and air blowers. One brand of phosphoric acid fuel cells claims their product emits only 60 db at 9 metres (Anon, 2005). The fuel cell stack itself is not a source of emissions as heat and water are the only products. The fuel reformer, however, produces trace amounts of NO_x and SO_x . Independent testing of a phosphoric acid fuel cell demonstrated NO_x levels less than 1.5 ppm (Anon, 2004).

4. 3. Heat boiler

Heat boilers represent perhaps the simplest use of anaerobic digester gas. Biogas can be used in heat boilers to directly produce high quality hot water or steam. The hot water or steam may be used to heat the digester and/or be used in secondary systems such as absorption chillers or space heaters. The gas could also be used directly in any natural gas fired appliance. When burning the gas in this way, it is recommended that levels of hydrogen sulfide not exceed 1000 ppm. When the concentration is higher, the sulfuric acid formed in the condensate can cause heavy corrosion (Wellinger and Lindberg, 2001). Many modern boilers have tin-laminated brass heat exchangers which can corrode more easily. Use of a cast iron heat exchanger can slow this corrosion. Ensuring the temperature of the exhaust gas is higher than 150 °C keeps the hydrogen sulfide above its dew point. The acid will not condense and therefore will contribute less to corrosion. Water vapour can cause problems in gas nozzles and may need to be removed.

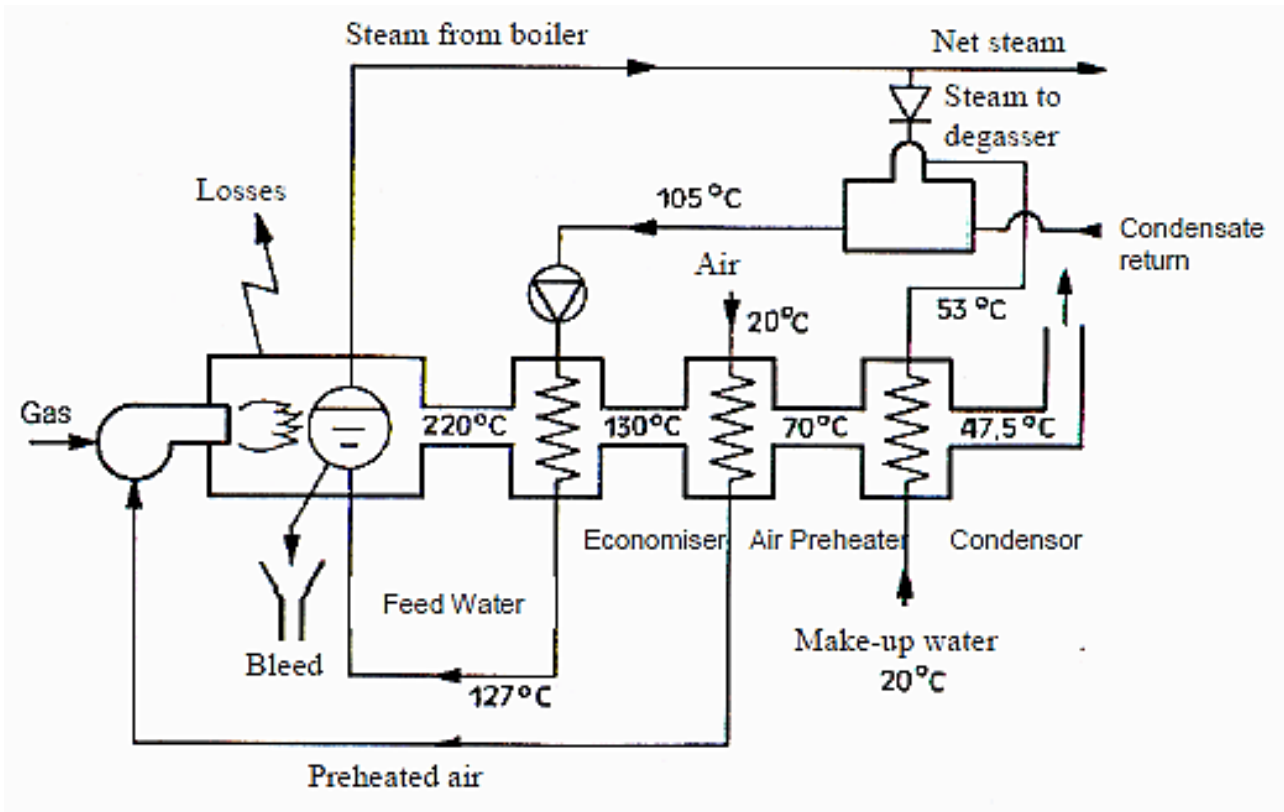

Figure 5. Production of steam from the boiler.

Removal of water will also remove a portion of the H₂S (Wellinger and Lindberg, 2001). The gas pressure requirements of a heat boiler are 0.80 to 2.50 kPa (0.12 to 0.36 psi). Digester-produced pressures are large enough for this demand.

Heat boilers are 80 to 90 % thermally efficient (Bitir et al, 2002). For example, consider a storage which contains 100 m³ of biogas with a methane content of 65 %. Since pure methane has a theoretical heat value of approximately 10 kWh/ m³, (approx 1000 BTU/ft³) the heat value of 100 m³ of biogas is 650 kWh. If the boiler is 80 % efficient, approximately 520 kWh are available for use.

4. 4. Internal Combustion Engines

The use of internal combustion (IC) engines with biogas is long established and reliable (Wellinger and Lindberg, 2001). IC engines are sub-divided into two categories: compression engines, and spark ignition engines.

Both types of engine may be converted to run on the biogas produced by anaerobic digesters.

Biogas operation of compression engines is known as “dual fuel” operation because a small amount of diesel fuel is combined with the gas for ignition purposes. Spark ignition engines are operated on a mixture of biogas and air, as ignition is caused by a spark p lug.

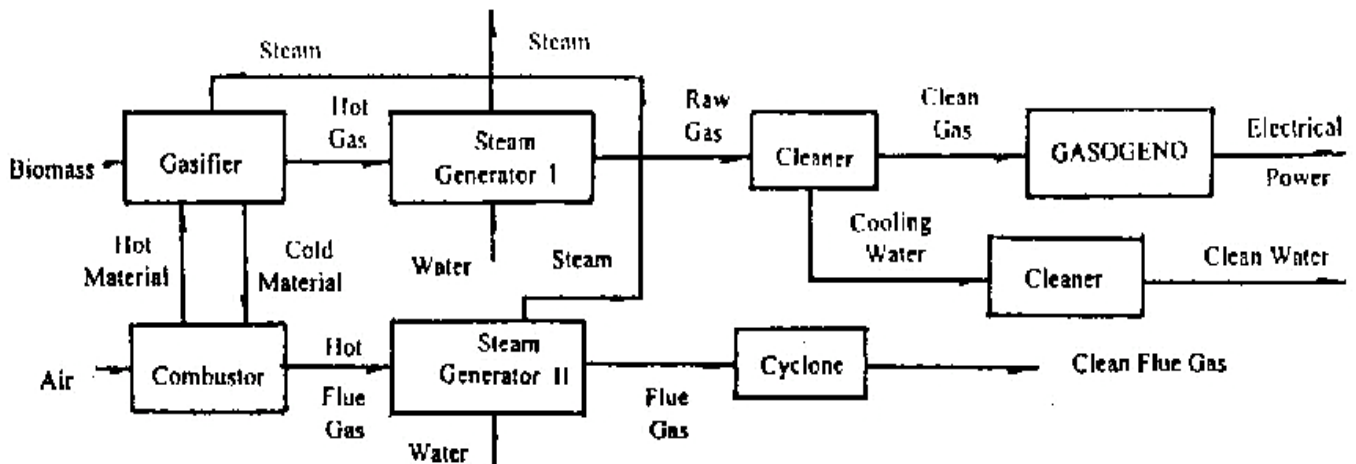

Figure 6. Application of biogas in internal combustion engine.

5. CONCLUSION

The energetic use of biogas causes different environmental and economical impacts depending on which system is used.

The electricity generation using biogas in landfills fulfills the electricity requirements of the plant and a surplus of energy can be delivered to the grid. In the agricultural sector the biogas produced, mainly in anaerobic digestors feed by manure residues, can provide energy surplus to, depending on the number of animals and the technology used to treat their residues.

References

- [1] Agstar. 2004. AgSTAR Handbook: A Manual for Developing Biogas Systems at Commercial Farms in the United States. Second Edition. U.S. Environmental Protection Agency and Environmental Restoration Group Inc.
- [2] Ahring, B.K. 1994. Status on Science and Application of Thermophilic Anaerobic Digestion. *Water Sci Tech* 30(12): 241-249.
- [3] Anaerobic Digesters: Design and Operation. Bulletin 827, The Pennsylvania State University, College of Agriculture, Agriculture Experiment Station. University Park, PA.
- [4] Anon. 2005. Fuels for Fuel Cells. National Fuel Cell Research Center. Available online at: <http://www.nfrcr.uci.edu/fcreources/FCexplained/Fuels.htm>. Date accessed: August 12, 2005.
- [5] Barker, J.C. 2001. Methane Fuel Gas from Livestock Wastes: A Summary Publication No. EBAE 071-80, North Carolina Cooperative Extension Service.
- [6] Belloso O.M., Fortuny R.S. 2011. Food Preservation Technology: advances in fresh-cut fruits and vegetables processing. 1-5.
- [7] Bitir, I., Tazerout, M. and Le Corre, O. 2002. Optimal Use of the Generated Biogas from Manure. Paper No. 387-395 in Proceedings of the World Congress of Computers in Agriculture and Natural Resources.
- [8] Brandon, R. 2002. The Power of New Technology: Microturbines. Natural Resources Canada. CANMET Energy Technology Centre, Nepean, ON.
- [9] Capstone. 2005. Capstone C30 Product Datasheet. Capstone Turbine Corporation, Chatsworth, CA.
- [10] Cristiani-Urbani, E., Netzahuatl-Munoz, A. R., Manriquez-Rojas, F. J., Juarez-Ramirez, C., Ruiz-Ordaz, N., and Galindez-Mayer, J. 2000 Batch and fed-batch cultures for the treatment of whey with mixed yeast cultures. *Proc. Biochem.* 35, 649-657.
- [11] Demirel, B., Yenigun, O., and Onay, T. T. 2005. Anaerobic treatment of dairy wastewaters: a review. *Proc. Biochem.* 40, 2583-2595.
- [12] Earth Tech. 2002. Waste-Based Energy Feasibility Study. Report submitted to Municipality of Chatham-Kent. Project No. 55484, Earth Tech Canada Inc. Markham, ON.
- [13] El-Mashad, H.M., Zeeman, G., van Loon, W.K.P., Bot, G.P. and Lettinga, G. 2004. Effect of temperature and temperature fluctuation on thermophilic anaerobic digestion of cattle manure. *Bioresource Tech.* 95: 191-201.
- [14] Fisher, J. R., Iannotti, E. L., & Fulhage, C. D. 1983. Production of methane gas from combinations of wheat straw and swine manure. *Trans. Am. Soc. Agricult. Eng.* 26, 546-548.
- [15] Gally, A. E. 1996. A comparative study of anaerobic digestion of acid cheese whey and dairy manure in a two-stage reactor. *Biores. Tech.* 58, 61-72.

- [16] Gelegenis, J., Georgakakis, D., Angelidaki, I., & Mavris, V. 2007. Optimization of biogas production by co-digestion whey with diluted poultry manure. *Renew. Energy* 32, 2147-2160.
- [17] Ingersoll-Rand. 2003. Biogas-to-Energy Systems for Anaerobic Digesters. Ingersoll-Rand Company, Davidson, NC.
- [18] Kacprzak, A., Krzystek, L., & Ledakowicz, S. 2010. Co-digestion of agricultural and industrial wates. *Chem. Pap.* 64, 127-131.
- [19] Kramer, J. 2002. Agricultural Biogas Casebook. Submitted to Great Lakes Regional Biomass Energy Program. Resource Strategies, Inc. Madison, WI.
- [20] Kushwaha, J. P., Srivastava, V. C., & Mall, I. D. 2010 Organics removal from dairy wastewater by electrochemical treatment and residue disposal. *Sep. and Purif. Technol.* 76, 198-205.
- [21] Memon M., Memon K.S., Mirani S., Jamro G.M. 2012 Comparative evaluation of organic wastes for improving maize growth and NPK Content. *Afr. J. Biotechnol.* 11: 39: 9343-9349.
- [22] Minott, S, Scott, N. and Aldrich, B. 2004. Feasibility Study of Fuel Cells for Biogas Energy Conversion on Large Dairy Farms. NSERDA. Technical Note FC-1.
- [23] NRC. 2002. The Power of New Technology – Microturbines. Natural Resources Canada – CANMET Energy Technology Centre.
- [24] NSTAR. 2005. Distributed Generation: Reciprocating Engines, Microturbines, Fuel Cells, Stirling Engines and Photovoltaics. NSTAR. Platts, McGraw-Hill Companies, Inc.
- [25] Persson, S.P.E., Bartlett, H.D., Branding, A.E., and Regan, R.W. 1979. Agricultural Pos, J., teBoekhorst, R., Eaton, D., Walczak, B. and Pavlicik, V. 1981. Biogas Production From Animal Manure and Crop Residues & Processes, *Procedure and Design. Technical Report* 126-59, 1981.
- [26] Poulsen, T.G. 2003. Anaerobic Digestion. Solid Waste Management, Ch. 5. Aalborg University, Aalborg, Denmark.
- [27] Price E.C. and Cheremisinoff, P.N. 1981. Biogas: Production & Utilization. Ann Arbor Science Publishers, Inc. Ann Arbor, MI.
- [28] Rajeshwari, K. V., Balakrishnan, B., Kansal, A., Lata, K., & Kishore, V. V. N. (2000). State-of-art of anaerobic digetion technology for industrial wastewater treatment. *Renew. and Sustain. Energy Rev.* 4, 135-156.
- [29] Rao, M.S., Singh, S.P. 2004 Bioenergy conversion of organic fraction of MSW: kinetic studies and gas yield-organic loading relationships for process optimization. *Bioresource Tech.* 95: 173-185.
- [30] Regassa N., Sundaraa R.D., Seboka B.B. 2011. Challenges and opportunities in municipal solid waste management: The case of Addis Ababa city, central Ethiopia. *J. Human Ecol.* 33(3): 179-190.
- [31] Six, J., Frey, S.D., Thiet, R.K., Batten, K.M., 2006. Bacterial and fungal contributions to C-sequestration in agro ecosystems. *Soil Science Society of America Journal* 70, 555-569.

- [32] Spece, R. E., 1999. Anaerobic biotechnology for industrial wastewater treatment. *Water Sci. Tech.* 23, 1259-1264.
- [33] Waldrop, M., Firestone, M.K., 2004. Microbial community utilization of recalcitrant and simple carbon compounds: impact of oak-woodland plant communities. *Oecologia* 138, 275-284.
- [34] Wellinger, A. and Lindberg, A. 2001. Biogas Upgrading and Utilisation. IEA Bioenergy. Task 24: Energy from biological conversion of organic waste.
- [35] Willingham, M. and Pipattanasomporn, M. 2003. The Role of Combined Heat and Power (CHP) in Virginia's Energy Future. Alexandria Research Institute. Alexandria, VA.
- [36] Wiltsee, G. and Emerson, H. 2004. Clean Power From Microturbines Using Biogas. *Biocycle* Feb. 45(2): 53-55.
- [37] Yadvika, Santosh, Sreekrishnan, T.R., Kohli, S., Rana, V. 2004 Enhancement of biogas production from solid substrates using different techniques – a review. *Bioresource Tech.* 95: 1-10.

(Received 15 January 2014; accepted 21 January 2014)