

Review article

Z. K. KROWICKI

ROLE OF SELECTED PEPTIDES IN THE VAGAL REGULATION OF GASTRIC MOTOR AND ENDOCRINE PANCREATIC FUNCTION

Department of Pharmacology and Experimental Therapeutics, Louisiana State University Medical Center, New Orleans, USA

The dorsal vagal complex (DVC) and nucleus raphe obscurus (nROb) are currently known to control vagal outflow to the stomach and the pancreas. Elucidation of neurotransmitters in these nuclei that control vagal outflow has become necessary to determine the endogenous circuitry for control of gastric motor activity and pancreatic hormone secretion. In this review, the author's data on the effects of selected peptides on intragastric pressure and gastric contractility as well as on pancreatic glucagon and insulin secretion in the DVC and nROb are presented. Microinjection of thyrotropin-releasing hormone (TRH) or pituitary adenylate cyclase-activating polypeptide (PACAP38) into the nROb results in gastric excitatory motor responses, whereas substance P (SP) and vasoactive intestinal polypeptide (VIP) evoke gastric relaxation. Irrespective of colocalization of TRH and SP in the serotonergic neurons of the nROb, these peptides independently affect gastric motor function when microinjected into the nROb. The inhibitory effect of SP on gastric motor function in the nROb is apparently mediated *via* nitric oxide in the DVC and involves peripheral VIP, acetylcholine, γ -aminobutyric acid and nitric oxide. Microinjection of endothelin, PACAP38, and VIP into the DVC evokes increases in gastric motor activity. Pancreatic polypeptide, microinjected into the DVC, does not affect basal plasma insulin and glucagon concentration but potentiates glucose-stimulated insulin secretion. All these data make an important contribution to our understanding of the vagal mechanisms controlling gastric motor and endocrine pancreatic function.

Key words: *dorsal motor nucleus of the vagus, dorsal vagal complex, endocrine pancreas, endothelin, gastric contractility, glucagon, insulin, intragastric pressure, L-arginine, L-NAME, nitric oxide, nucleus raphe obscurus, pancreatic polypeptide, pituitary adenylate cyclase-activating polypeptide, serotonin, substance P, thyrotropin-releasing hormone, vagotomy, vagus, vasoactive intestinal polypeptide.*

INTRODUCTION

The vagus nerve provides parasympathetic control of the gastrointestinal (GI) tract and the pancreas. Gastrointestinal and pancreatic parasympathetic preganglionic neurons originate in the dorsal motor nucleus of the vagus

(DMV) in the dorsomedial medulla oblongata. This nucleus is a part of the dorsal vagal complex (DVC), including also the nucleus of the solitary tract (nTS), that serves as a critical interface between periphery visceral pathways and the central nervous system in the regulation of autonomic functions. The neuronal inputs to the DVC are from numerous local and descending projectings so the overall activity of the parasympathetic outflow may be influenced by many different central cell groups. One of these inputs to the DVC is from the medullary raphe nuclei (for review see: 1).

The DVC is a likely location for interaction between the neural and hormonal signals that modulate GI and pancreatic function. The proximity of the DMV and nTS to the cerebrospinal fluid bathing the fourth ventricle and their close anatomical association to the area postrema provides routes through which blood-borne substances may reach specific receptors within the DVC. Highly permeable capillaries within the area postrema and many neural efferent outputs that emanate from this circumventricular organ to the DMV, nTS, and other brainstem nuclei (2) make this interaction possible. In addition, the dorsomedial and lateral commissural subnuclei of the nTS can be exposed to circulating agents directly *via* their own specialized and permeable microcirculation (3).

The raphe nuclei in the caudal medulla oblongata, including the nROb and the nucleus raphe pallidus, have recently emerged as important structures involved in the brain control of gastric and endocrine pancreatic function (for review see: 1 and 4). These raphe nuclei have been shown to maintain direct anatomic connections with the DVC and receive numerous afferent projections from hypothalamic and hindbrain sites (for review see: 1). My morphological studies, utilizing colloidal gold retrograde tracer, have demonstrated that these afferents are distinct and separate from projections to the DMV (5). Moreover, I have demonstrated that chemical stimulation of the nROb cell bodies with L-glutamate, an excitatory amino acid (EAA), in the rat evokes significant increases in gastric tone and contractility (6). These results confirmed earlier communication about excitatory effects of L-glutamate in the nROb on gastric motor function in the rat (7). Therefore, these brainstem nuclei have become a focus of my studies to elucidate the neuroactive substances involved in the brain control of gastric motor and endocrine pancreatic function. A summary of these effects is shown in *Fig. 1*.

Findings of coexistence of thyrotropin-releasing hormone (TRH) and substance P (SP) in the serotonergic neurons of the caudal raphe nuclei (8), prompted us to investigate the effect of microinjection of these substances into the nROb on intragastric pressure and gastric smooth muscle contractility. Our anatomic studies demonstrated the existence of numerous afferent serotonergic projections arising from medullary and pontine serotonin (5-HT)-containing neurons to the nROb (9). I have shown that microinjection

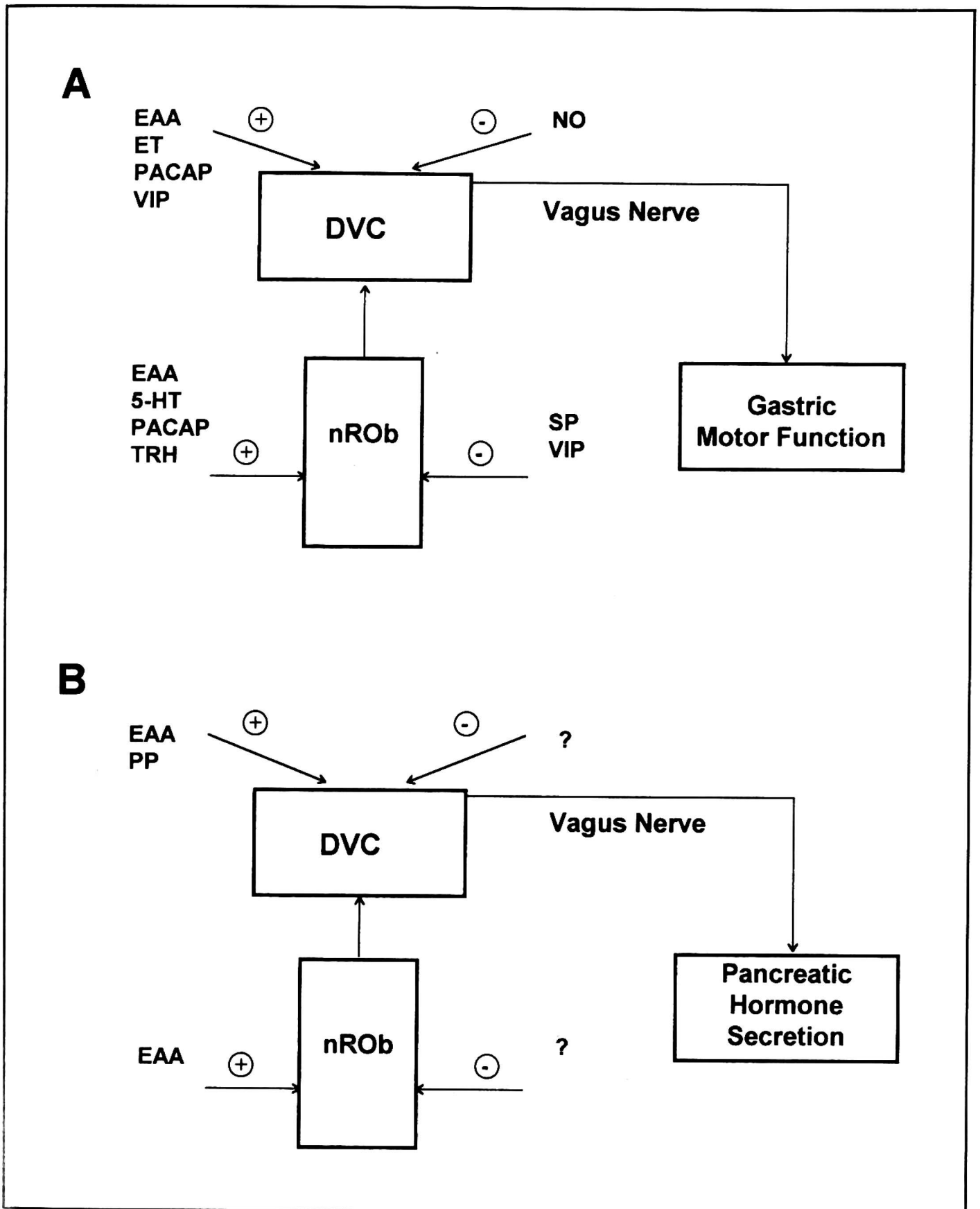

Fig. 1. Schematic illustration of caudal raphe-DVC-vagal pathway that controls gastric motor (A) and pancreatic endocrine (B) function. Selected agents, microinjected into the raphe nuclei or the DVC, evoke increases (+) or decreases (-) in gastric tone and contractility (A) and plasma insulin and glucagon concentration (B). Abbreviations: EAA, excitatory amino acids; DVC, dorsal vagal complex; ET, endothelin; 5-HT, serotonin; NO, nitric oxide; nROb, nucleus raphe obscurus; PACAP, pituitary adenylate cyclase-activating polypeptide; PP, pancreatic polypeptide; SP, substance P; TRH, thyrotropin-releasing hormone; VIP, vasoactive intestinal polypeptide, ?, unknown.

of 5-HT into the nROb increased intragastric pressure, although gastric contractility was not significantly altered (6). The precise pathways and mechanisms by which 5-HT in the nROb increases intragastric pressure are not known, but may be through activation of TRH-containing nROb neurons that project to the DMV (10).

My recent studies have shown that TRH, microinjected into the nROb, evokes dose-dependent increases in gastric motor function and this effect is mediated through the cholinergic vagal fibers (11). Similarly, microinjection of a stable TRH analog RX 77368 into the nROb or nucleus raphe pallidus has been also reported to increase gastric motor function (12). It is possible that microinjection of TRH into the nROb activates TRH bodies in the nROb that project to the DMV (10) and, finally, stimulates gastric motility (13). Since electrical stimulation of the medullary raphe region induces a sustained (lasting for 1 hour) increase of the extracellular level of 5-HT *in vivo* in the cat DVC (14), it is possible that TRH in the nROb also activates 5-HT bodies in the nucleus that project to the DVC (15). There is evidence supporting a role of 5-HT in control of gastric motility in the DVC when combined with TRH (16). I have also demonstrated that SP, microinjected into the nROb, dose-dependently inhibits gastric motor function, that is abolished by bilateral vagotomy, but not by spinal cord transection or atropine (11). This observation led us to speculation of the nROb-DMV pathway that could result in inhibition of gastric motor function *via* vagal efferent fibers.

Colocalization of TRH and SP in the serotonergic neurons of the raphe nuclei (8) was the rationale to investigate functional interactions between these agents in the nROb to mediate changes in gastric motor function. By microinjecting TRH, 5-HT, and SP into the nROb as a mixture and in rapid sequential order I found no functional interaction of TRH and 5-HT (17), TRH and SP (18), and SP and 5-HT (19). Of course, the possibility of interactions of TRH, SP, and 5-HT at a cellular/molecular level in response to microinjections of the agents cannot be ruled out. However, this does not appear to influence the ultimate result, which occurs through vagal control of the stomach.

In another series of experiments I attempted to investigate the mechanisms by which SP in the nROb evokes gastric motor inhibition. A summary of these mechanisms is shown in *Fig. 2*.

We have recently demonstrated that NADPH-diaphorase [a marker of nitric oxide synthase (NOS) activity] staining and NOS immunoreactivity are present in neurons and fibers or terminals in the DVC (20). We have also characterized the distribution of NOS in preganglionic neurons of the DMV (21). The latter observation suggests that the population of NOS-containing preganglionics in the DMV may release nitric oxide (NO) *via* the vagus nerve onto postganglionic neurons and promote adaptive relaxation and decreased motility of the upper GI tract. Moreover, I have shown recently that

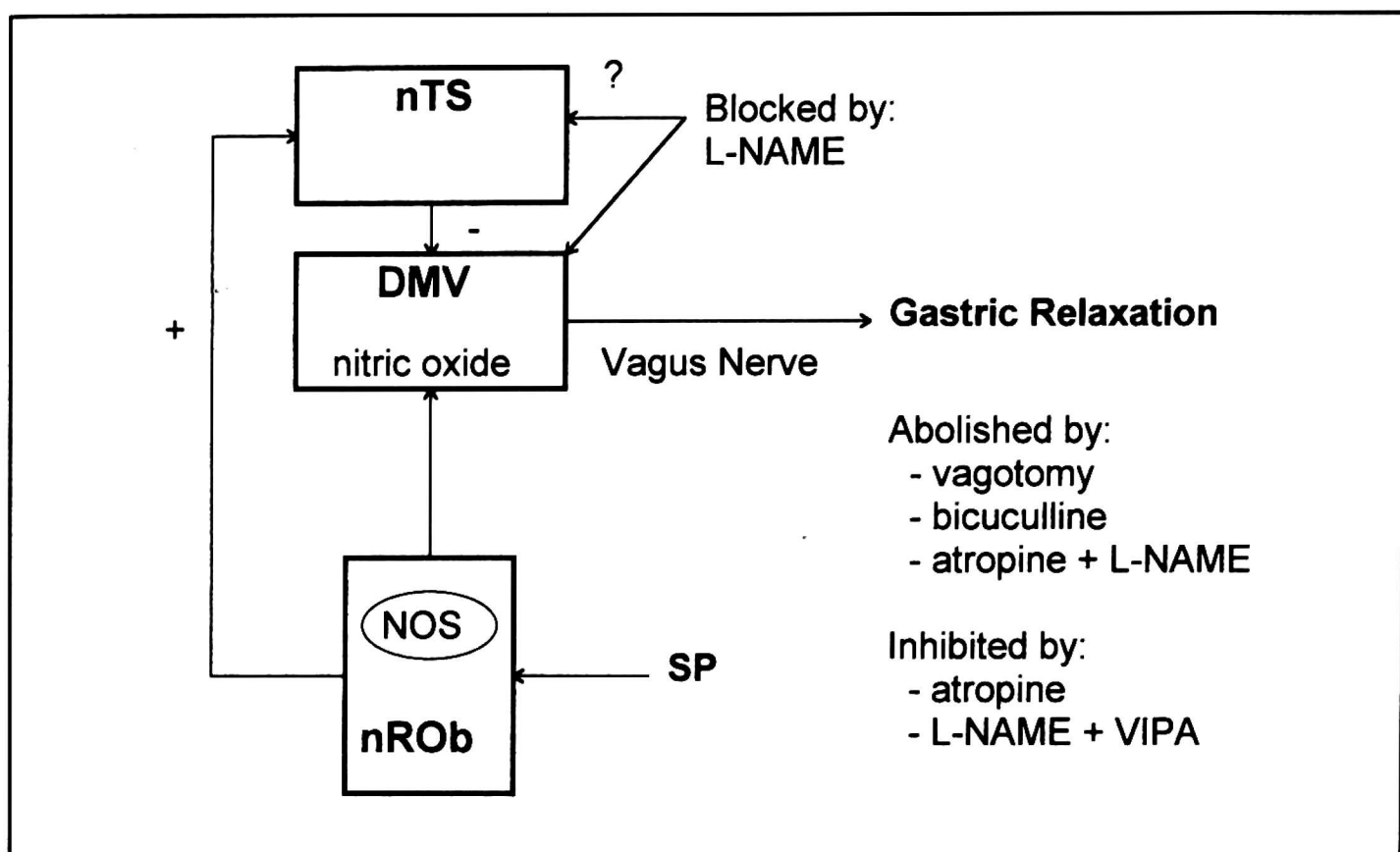

Fig. 2. Potential mechanisms of SP-evoked gastric relaxation. Substance P may selectively activate NOS-containing neurons in the nROb, projecting to the MDV or may activate pathways to the nTS that decrease intragastric pressure through afferent-efferent connections in the DVC (DMV + nTS). Inhibition of NOS in the DVC and peripheral administration of GABA_A receptor antagonist, bicuculline, or atropine combined with L-NAME abolishes SP-elicited gastric relaxation. Peripheral atropine reduces both the rapid and sustained gastric relaxation and NOS inhibitor combined with VIP antagonist reduces the sustained gastric relaxation evoked by SP in the nROb. Abbreviations: DMV, dorsal motor nucleus of the vagus; NOS, nitric oxide synthase; nROb, nucleus raphe obscurus; nTS, nucleus of the solitary tract; L-NAME, N^G-nitro-L-arginine methyl ester; SP, substance P; VIPA, vasoactive intestinal polypeptide antagonist.

L-arginine, a substrate for NOS, microinjected into the DVC, evokes decreases in intragastric pressure and NOS inhibition with N^G-nitro-L-arginine methyl ester (L-NAME) has the opposite effect (20).

To test the hypothesis that SP in the nROb mediates gastric motor inhibition *via* NO in the DVC, SP was microinjected into the nROb immediately after bilateral microinjection of L-NAME into the DVC. Inhibition of NOS in the DVC almost completely blocked the inhibitory gastric effects of SP in the nROb (22). Therefore, SP in the nROb activates NO in the DVC to mediate the inhibitory effect on intragastric pressure.

Recently, Krantis *et* Glasgow (23) have reported that the blockade of γ -aminobutyric acid (GABA)_A receptors significantly reduced or even abolished antral relaxations in the anesthetized rat. Therefore I decided to investigate the involvement of peripheral GABA in mediating the inhibitory gastric motor effects of SP in the nROb. The results of my experiments showed that blockade of GABA_A receptors is sufficient alone to prevent the central

effect of SP to cause gastric relaxation and inhibition of gastric contractility (24). Therefore, I concluded that SP-evoked gastric relaxation in the nROb is mediated through a peripheral GABAergic pathway.

The vagus nerve plays an important role in the mediation of receptive relaxation through non-adrenergic, non-cholinergic (NANC) innervation to the stomach and both NO and vasoactive intestinal polypeptide (VIP) have been proposed as inhibitory transmitters of NANC neurons. It has been suggested that NO initiates (rapid relaxation) and VIP sustains (delayed relaxation) the NANC relaxation (25). Therefore, we compared the gastric inhibitory motor effects of SP in the nROb before and after systemic administration of cholinergic (atropine methyl bromide) and VIP ([pCl-D-Phe⁶, Leu¹⁷]VIP) antagonists and L-NAME alone or in combination. Atropine reduced both the rapid nadir and sustained gastric relaxation evoked by SP in the nROb, and the residual responses were abolished by L-NAME (26). These results are consistent with a role of NO and acetylcholine as functional antagonists controlling intragastric pressure, with cholinergic tone contributing to the nadir and sustained gastric relaxation and NO playing a more predominant role in the sustained gastric relaxation. These data do not indicate that the only contribution of NO is to provide presynaptic inhibition of acetylcholine release (27), since if this was the case, L-NAME after atropine would not be expected to further decrease intragastric pressure. Our data indicate that inhibition of acetylcholine, alone or combined with another NANC transmitter, mediates the rapid gastric relaxation in response to SP in the nROb. The most possible explanation is that NO presynaptically inhibits acetylcholine release either at the ganglion or in myenteric plexus (27).

A VIP antagonist, alone or with the addition of L-NAME did not affect the nadir of the decrease in intragastric pressure; however, both antagonists reduced the SP-evoked gastric relaxation (26). Vasoactive intestinal polypeptide is thought to mediate long lasting gastric relaxation (28), therefore, we expected that antagonism of VIP alone would decrease the inhibitory gastric response to SP in the nROb. The fact that blockade of both VIP and NOS was required to completely abolish the sustained gastric relaxation suggests that both neurotransmitters are required to mediate this response. In summary, the results of our study indicate that neither VIP nor NOS antagonism abolish the gastric motor response to SP in the nROb and that inhibition of cholinergic pathways is potentially important for the rapid and sustained gastric relaxation. Moreover, both NO and VIP contribute to sustained gastric relaxation. A reduction of intragastric pressure by microinjection of SP into the nROb provides a reliable and repeatable model of vagally-mediated gastric relaxation.

My recent study demonstrated that microinjection of VIP into the nROb evoked decreases in gastric tone and contractility and that these effects were mediated through vagal pathways (29). Since VIP shows high sequence

homology with pituitary adenylate cyclase-activating polypeptide (PACAP) and PACAP is usually considered as a potential ligand of VIP receptors (30). I studied the effect of microinjection of PACAP38 into the nROb on gastric motor function. Microinjection of PACAP38 into the nROb evoked dose-dependent increases in intragastric pressure (29).

Opposite gastric motor effects of VIP and PACAP38 in the nROb (29), prompted us to investigate the effects of microinjection of these peptides into the DVC. We have demonstrated that both VIP (31) and PACAP38 (32), microinjected into the DVC, evoke increases in gastric motor function and these effects are abolished by bilateral vagotomy.

Endothelin (ET) is another vasoactive agent with wide spectrum of both vascular and nonvascular actions in a variety of tissues, including the GI tract (33). Endothelin binding sites have been localized in the DVC (34, 35). However, the involvement of ET in cardiovascular regulation in the DVC has been only investigated (36). Elevated plasma ET concentrations in diabetic patients (37—39) in whom GI transit disorders are relatively common, prompted me to investigate the central effects of ET on gastric motor function. In the first study, two ET isoforms, namely ET-1 and ET-3, of which ET-1 is of peripheral origin and ET-3 is expressed in the CNS but not in the vascular epithelium (40), were applied to the dorsal surface of the medulla oblongata. Both ET-1 and ET-3 increased intragastric pressure and stimulated gastric contractility (41). My further experiments revealed that ET-1 and ET-3, microinjected into the DVC, increased gastric motor function in anesthetized rats (42) and the specific ET_A receptor antagonist, BQ-123 (43), blocked the gastric motor responses to ET-1 in the DVC (unpublished observations). Therefore, these findings indicate that the gastric motor effects of ET-1 in the DVC are mediated through ET_A receptors.

Anatomical studies revealed that efferent vagal terminals in the pancreas originate in the DMV and provided detailed information as to the morphology and distribution of efferent vagal innervation to the pancreas (44). The overall activity of the parasympathetic outflow to the pancreas is apparently influenced by many different central cell groups. One of these inputs is from the medullary raphe nuclei that synapse on the pancreatic parasympathetic preganglionic neurons of the DMV (45). Therefore, I decided to investigate the role of the nROb and DVC in the regulation of pancreatic hormone secretion. My recent study has shown that chemical stimulation with kainic acid, an EAA producing a long-lasting excitation (46), increased plasma concentrations of insulin and glucagon (47). The increases in plasma concentrations of insulin and glucagon in response to stimulation of nROb neurons were of a similar magnitude and time course as those observed on stimulation of the DVC. The vagus nerve is the primary autonomic pathway by which these effects are mediated because bilateral vagotomy completely abolishes the effect of kainic acid in the nROb on plasma insulin and glucagon concentrations (47).

My recent study has shown that chemical stimulation of the DVC neurons results in elevated plasma insulin and glucagon concentrations (47). It has been shown that pancreatic polypeptide (PP) of peripheral origin may reach its specific receptors within the DVC (48). Moreover, administration of PP into the cisterna magna or its microinjection into the DVC of the rat has been reported by other investigators to increase gastric emptying (49, 50) and gastric contractility (51). Therefore, I speculated that PP, known to be released postprandially by a mixed meal (53, 54), may affect pancreatic insulin and glucagon secretion in the DVC. To test this hypothesis I investigated whether PP, microinjected into the DVC, affects endocrine pancreatic function. The second question addressed in my study was to determine whether PP could affect glucose-stimulated insulin secretion. I have demonstrated that rat PP, microinjected into the DVC of the rat, enhances the insulinotropic action of glucose, but does not affect basal plasma insulin and glucagon concentrations (55).

All these data make an important contribution to our understanding of the vagal mechanisms controlling gastric motor and endocrine pancreatic function.

CONCLUSIONS

1. The lower brainstem nuclei, namely the nROb and DVC, play a role in the vagal regulation of gastric motor and endocrine pancreatic function.
2. Thyrotropin-releasing hormone and PACAP38 in the nROb evoke excitatory gastric motor responses, whereas SP and VIP, in the same nucleus, elicit gastric relaxation.
3. Irrespective of colocalization of TRH and SP in the serotonergic neurons of the nROb, these peptides independently affect gastric motor function in the nROb.
4. The inhibitory effect of SP in the nROb on gastric motor function is mediated *via* NO in the DVC.
5. In the SP-evoked gastric relaxation, inhibition of cholinergic pathways is potentially important for both the rapid nadir and sustained gastric relaxation and NO and VIP contribute to sustained gastric relaxation.
6. Substance-P evoked gastric motor inhibition is mediated through a peripheral GABAergic pathway.
7. Vasoactive intestinal polypeptide and PACAP38 in the DVC elicit excitatory gastric motor responses.
8. The DVC is the main lower brainstem region where the gastric excitatory motor effects of ET are mediated.
9. Pancreatic polypeptide, microinjected into the DVC, potentiates glucose-stimulated insulin secretion.

REFERENCES

1. Tache Y, Yang H, Kaneko H. Caudal raphe-dorsal vagal complex peptidergic projections: role in gastric vagal control. *Peptides* 1995; 16: 431—435.
2. Shapiro RE, Miselis RR. The central neural connections of the area postrema of the rat. *J Comp Neurol* 1985; 234: 244—364.
3. Gross PM, Wall KM, Pang JJ, Shaver SW, Wainman DS. Microvascular specializations promoting rapid interstitial solute dispersion in nucleus tractus solitarius. *Am J Physiol* 1990; 259: R1131—R1138.
4. Krowicki ZK, Hornby PJ. Hindbrain Neuroactive Substances Controlling Gastrointestinal Function. In: *Regulatory Mechanisms in Gastrointestinal Function* TS, Gaginella (ed.) Boca Raton: CRC Press, Inc. 1995: pp. 277—319.
5. Krowicki ZK, Hornby PJ. Nucleus raphe obscurus in control of gastrointestinal function: Afferent pathways. *Soc Neurosci Abst* 1991, 17: 1366.
6. Krowicki ZK, Hornby PJ. Serotonin microinjected into the nucleus raphe obscurus increases intragastric pressure in the rat via a vagally mediated pathway. *J Pharmacol Exp Ther* 1993; 265: 468—476.
7. McCann MJ, Hermann GE, Rogers RC. Nucleus raphe obscurus (nRO) influences vagal control of gastric motility in rats. *Brain Res* 1989; 486: 181—184.
8. Kachidian P, Poulat P, Marlier L, Privat A. Immunohistochemical evidence for the coexistence of substance P, thyrotropin-releasing hormone, GABA, methionine-enkephalin, and leucine-enkephalin in the serotonergic neurons of the caudal raphe nuclei- a dual labeling in rat. *J Neurosci Res* 1991; 30: 521—530.
9. Hornby PJ, Krowicki ZK. Hindbrain serotonergic nuclei project to the 'gastric' region of the nucleus raphe obscurus. *Gastroenterology* 1992; 102 (Suppl.): A459.
10. Lynn RB, Kreider MS, Miselis RR. Thyrotropin-releasing hormone-immunoreactive projections to the dorsal motor nucleus and the nucleus of the solitary tract of the rat. *J Comp Neurol* 1991; 311: 271—288.
11. Krowicki ZK, Hornby PJ. Opposing gastric motor responses to TRH and substance P on their microinjection into nucleus raphe obscurus of rats. *Am J Physiol* 1993; 265: G819—G830.
12. Garrick T, Yang H, Trauner M, Livingston E, Tache Y. Thyrotropin-releasing hormone analog injected into the raphe pallidus and obscurus increases gastric contractility in rats. *Eur J Pharmacol* 1992, 223: 75—81.
13. Hornby PJ, Rossiter CD, Pineo SV et al. TRH: Immunocytochemical distribution in vagal nuclei of the cat and physiological effects of microinjection. *Am J Physiol* 1989; 257: G454—G462.
14. Brodin E, Linderoth B, Goigny M et al. In vivo release of serotonin in cat dorsal vagal complex and cervical ventral horn by electrical stimulation of the medullary raphe nuclei. *Brain Res* 1990; 535: 277—236.
15. Thor KB, Hlke CJ. Serotonin- and substance P-containing projections to the nucleus tractus solitarii of the rat. *J Comp Neurol* 1987; 265: 275—293.
16. McCann MJ, Hermann GE, Rogers RC. Dorsal medullary serotonin and gastric motility: Enhancement of effects of thyrotropin-releasing hormone. *J Auton Nerv Syst* 1988; 25: 35—40.
17. Krowicki ZK, Hornby PJ. Serotonin and thyrotropin-releasing hormone do not augment their effects on gastric motility on their microinjection into the nucleus raphe obscurus of the rat. *J Pharmacol Exp Ther* 1995; 273: 499—508.
18. Krowicki ZK, Hornby PJ. TRH and substance P independently affect gastric motility in nucleus raphe obscurus of the rat. *Am J Physiol* 1994; 266: G870—G877.

19. Krowicki ZK, Hornby PJ. Substance P and serotonin independently affect intragastric pressure when microinjected into the nucleus raphe obscurus of the rat. *J Auton Nerv Syst* 1995; 51: 175—179.
20. Krowicki ZK, Sharkey KA, Cardoza SV, Nathan NA, Hornby PJ. Distribution of nitric oxide synthase in rat dorsal vagal complex and effects of microinjection of NO compounds upon gastric motor function. *J Comp Neurol* 1996; (In Press).
21. Hornby PJ, Nathan NA, Sharkey KA, Krowicki ZK. Distribution of NO synthase in preganglionic neurons of the vagal dorsal motor nucleus. *Neurogastroenterol Motil* 1995; 7: 126.
22. Krowicki ZK, Hornby PJ. The inhibitory effect of substance P on gastric motor function in the nucleus raphe obscurus is mediated via nitric oxide in the dorsal vagal complex. *J Auton Nerv Syst* 1996; 58: 177—180.
23. Krantis A, Glasgow I. Relaxations of the rat gastroduodenum *in vivo* occur within distinct patterns and utilise different transmitters. *Gastroenterology* 1995; 108: A632.
24. Krowicki ZK, Hornby PJ. Bicuculline blocks the inhibitory effects of substance P but not vasoactive intestinal polypeptide on gastric motor function in the nucleus raphe obscurus of the rat. *Inflammopharmacology* 1996; 4: in press.
25. Takahashi T, Owyang C. Vagal control of nitric oxide and vasoactive intestinal polypeptide release in the regulation of gastric relaxation in rat. *J Physiol* 1995; 484: 481—492.
26. Krowicki ZK, Hornby PJ. Contribution of acetylcholine, vasoactive intestinal polypeptide and nitric oxide to CNS-evoked vagal gastric relaxation in the rat. *Neurogastroenterol Motil* 1996; (In Press).
27. Baccari MC, Calamai F, Staderini G. Modulation of cholinergic transmission by nitric oxide, VIP and ATP in the gastric muscle. *Neuroreport* 1994; 5: 905—908.
28. Lefebvre RA, De Vriese A, Smits JM. Influence of vasoactive intestinal polypeptide and N^G-nitro-L-arginine methyl ester on cholinergic transmission in the rat gastric fundus. *Eur J Pharmacol* 1992; 221: 235—242.
29. Krowicki ZK, Arimura A, Hornby PJ. Opposite gastric motor effects of PACAP38 and VIP when microinjected into the nucleus raphe obscurus of rats. *Ann N Y Acad Sci* 1996; (In Press).
30. Sreedharan SP, Huang J-X, Cheung M-C, Goetzl EJ. Structure, expression, and chromosomal localization of the type I human vasoactive intestinal polypeptide receptor gene. *Proc Natl Acad Sci USA* 1995; 92: 2939—2943.
31. Krowicki ZK, Hornby PJ. Evidence for opposing effects of vasoactive intestinal polypeptide (VIP) on gastric motor function in the dorsal vagal complex (DVC) and nucleus raphe obscurus (nRO) of the rat. *Soc Neurosci Abstr* 1995; 21: 1016.
32. Hornby PJ, Legradi G, Arimura A, Krowicki ZK. Effects of pituitary adenylate cyclase-activating polypeptide (PACAP) on gastric motor function in the brainstem of the rat. *Soc Neurosci Abstr* 1994; 20: 1377.
33. Rae GA, Calixto JB, D'Orleans-Juste P. Effects and mechanisms of action of endothelins on non-vascular smooth muscle of the respiratory, gastrointestinal and urogenital tracts. *Regul Pept* 1995; 55: 1—46.
34. van den Buuse M, Itoh S. Central effects of endothelin on baroreflex of spontaneously hypertensive rats. *J Hypertens* 1993; 11: 379—387.
35. Kohzuki M, Chai SY, Paxinos et al. Localization and characterization of endothelin receptor binding sites in the rat brain visualized by *in vitro* autoradiography. *Neuroscience* 1991; 42: 245—260.
36. Mosqueda-Garcia R, Inagami T, Appalsamy M, Sugiura M, Robertson RM. Endothelin as a neuropeptide. Cardiovascular effects in the brainstem of normotensive rats. *Circ Res* 1992; 72: 20—35.

37. Morise T, Takeuchi Y, Kawano M, Koni I, Takeda R. Increased plasma levels of immunoreactive endothelin and von Willebrand factor in NIDDM patients. *Diabetes Care* 1995; 18: 87—89.
38. Zeng ZP, Tang D, Sun ML. The relationship between the plasma levels of endothelin and angiopathy in diabetic patients. *Chung Hua Nei Ko Tsa Chih* 1994; 33: 467—469.
39. Donatelli M, Colletti I, Bucalo ML, Russo V, Verga S. Plasma endothelin levels in NIDDM patients with macroangiopathy. *Diabetes Res* 1994; 25: 159—164.
40. MacCumber MW, Ross CA, Snyder SH. Endothelin in brain: Receptors, mitogenesis, and biosynthesis in glial cells. *Proc Natl Acad Sci USA* 1990; 87: 2359—2363.
41. Krowicki ZK, Hornby PJ. Gastric motor effects of endothelins in the lower brainstem of the rat. *Inflammopharmacology* 1996; (In Press).
42. Krowicki ZK, Hornby PJ. Gastric motor effects of endothelin in the lower brainstem of the rat. *Dig Dis Sci* 1995; 41: 445.
43. Ihara M, Noguchi K, Saeki T. et al. Biological profiles of highly potent novel endothelin antagonists selective for the ET_A receptor. *Life Sci* 1992; 50: 247—255.
44. Berthoud H-R, Powley TL. Morphology and distribution of efferent vagal innervation of rat pancreas as revealed with anterograde transport of Dil. *Brain Res* 1991; 553: 336—341.
45. Loewy AD, Franklin MF, Haxhiu MA. CNS monoamine cell groups projecting to pancreatic vagal motor neurons: A transneuronal labeling study using pseudorabies virus. *Brain Res* 1994; 638: 248—260.
46. Ben-Ari Y, Tremblay E, Ottersen OP. Injections of kainic acid into the amygdaloid complex of the rat: An electrographic, clinical and histological study in relation to the pathology of epilepsy. *Neuroscience* 1980; 5: 515—528.
47. Krowicki ZK, Hornby PJ. The nucleus raphe obscurus controls pancreatic hormone secretion in the rat. *Am J Physiol* 1995; 268: E1128—E1134.
48. Whitcomb DC, Taylor IL, Vigna SR. Characterization of saturable binding sites for circulating pancreatic polypeptide in rat brain. *Am J Physiol* 1990; 259: G687—G691.
49. Okumura T, Pappas TN, Taylor IL. Intracisternal injection of pancreatic polypeptide stimulates gastric emptying in rats. *Neurosci Lett* 1994; 178: 167—170.
50. McTigue DM, Chen CH, Rogers RC, Stephens RL, Jr. Intracisternal rat pancreatic polypeptide stimulates gastric emptying in the rat. *Am J Physiol* 1995; 269: R167—R172.
51. McTigue DM, Edwards NK, Rogers RC. Pancreatic polypeptide in dorsal vagal complex stimulates gastric acid secretion and motility in rats. *Am J Physiol* 1993; 265: G1169—G1176.
52. Schwartz TW. Pancreatic polypeptide: A hormone under vagal control. *Gastroenterology* 1983; 85: 1411—1425.
53. Taylor IL, Impicciatore M, Carter DC, Walsh JH. Effect of atropine and vagotomy on pancreatic polypeptide response to a meal in dogs. *Am J Physiol* 1978; 235: E443—E447.
54. Lee W, Miyazaki K, Funakoshi A. Effects of somatostatin and pancreatic polypeptide on exocrine and endocrine pancreas in the rats. *Gastroenterol Jpn* 1988; 23: 49—55.
55. Krowicki ZK, Hornby P. Pancreatic polypeptide, microinjected into the dorsal vagal complex, potentiates glucose-stimulated insulin secretion in the rat. *Regul Pept* 1995; 60: 185—192.

Received: May 18, 1996

Accepted: June 19, 1996

Author's address: Z Krowicki, Department of Pharmacology, LSUMC, 1901 Perdido Street, New Orleans, LA 70112, USA.