

## INFLUENCE OF ELECTROSTRICTION FORCES ON ENERGY CONSUMPTION OF DRYING GRAIN SEEDS IN A DRUM DRIER

*W. Pietrzyk<sup>1</sup>, M. Horyński<sup>1</sup>, M. Ścibisz<sup>2</sup>*

<sup>1</sup>Department of General Electric, Faculty of Fundamental Engineering, Technical University  
Nadbystrzycka 38 A, 20-618 Lublin, Poland

<sup>2</sup>Department of Electrical Engineering, University of Agriculture  
Doświadczalna 50 A, 20-280 Lublin, Poland

*Accepted February 2, 1996*

**A b s t r a c t.** In this paper, the results of studies on energy consumption in the process of grain seeds drying are presented. Tarushkin's hypothesis forms the basis of these studies according to which positive and negative tensile stresses that arise in an electrostatic field produce micro changes in grain structure. These changes may manifest themselves in reducing the capability to keep the moisture and thereby reducing the energy consumption in the process of conventional drying.

**Key words:** grain seeds, energy, dielectric drying, electric field

### INTRODUCTION

The paper compares the results of studies on energy consumption in the process of grain drying; conventionally dried in a drum drier vs dried grain seeds acted by electrostatic field. The aim of this research was to verify Tarushkin's hypothesis [5] which suggests that positive and negative tensile stresses that arise in an electrostatic field produce microchanges in grain structure. These changes may manifest themselves in reducing the moisture retention capacity and thereby reducing the energy consumption in the process of conventional drying.

On the basis of this research we can find out whether there are certain values of the electrical field intensity for which we can achieve energy saving in drying grain seeds.

Results presented in this article show positive changes of energy consumption in grain drying. The study includes drying of barley, rye and oat seed samples.

### MATERIALS AND METHODS

The drying processes was carried out with a prototype drum drier constructed in the Department of Electrical Engineering, University of Agriculture in Lublin, Poland. Some changes introduced to the model described by Krakowiak and Pietrzyk [3] consist in the electrical isolation of the inner shaft from the outer cylinder. High voltage from a high voltage supplier is connected across the outer cylinder and the inner shaft. Then an electric field occurs in the space between the outer cylinder and the inner shaft. Figure 1 shows a diagram of a drying chamber.

The drying chamber consists of a cylinder (1) which comprises a central shaft (2). It enables axial rotation of the cylinder. High voltage ( $U$ ) applied to the cylinder and the shaft generates, inside the chamber, the electrical field of the intensity ( $E$ ) described by the following relation:

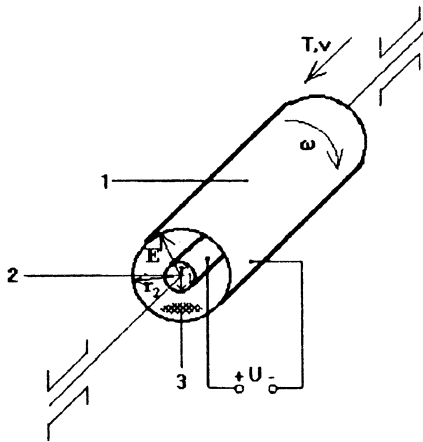

**Fig. 1.** Diagram of drying chamber: 1 - outer cylinder; 2 - inner shaft; 3 - dried seeds;  $U$  - voltage between the electrodes;  $r_2$  - outer cylinder radius;  $r_1$  - inner shaft radius;  $r$  - radius of the spot where we compute the field intensity;  $\omega$  - angular velocity of air stream;  $T$  - temperature of air stream.

$$E = \frac{U}{r \ln \frac{r_2}{r_1}} \quad (1)$$

where  $U$  is voltage between the electrodes kV;  $r_1$  - inner shaft radius, m;  $r_2$  - outer cylinder radius, m;  $r$  - radius of the spot where we compute the field intensity, m.

The field influences the seeds that are being dried. During the drying, a layer of the seeds deposits on the internal surface of the drying chamber outer cylinder. The electric field intensity values within the dried substance can be computed from Eq.(1). Considering that the dried seed deposit is of negligible thickness, its electric field intensity can be approximately determined from Eq.(2):

$$E = \frac{U}{r_2 \ln \frac{r_2}{r_1}} \quad (2)$$

Figure 2 shows the linear dependence of the field intensity in the dried layer in the drier investigated.

Figure 3 presents a general layout of the laboratory stand.

During the experiments the seeds are introduced into a charging hopper box (7) which

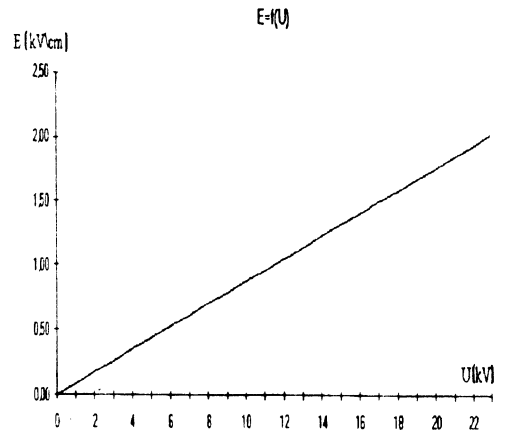

**Fig. 2.** The dependence of the field intensity in the dried layer in the investigated drier vs. applied voltage.

pass into the drying chamber (1). The supplier (4) allows control of the rotational speed of the drum. Hot air of controlled temperature from the heater (3) enters through the drum inlet and exits through the drum outlet. Controlled voltage provided by a high voltage supply is applied (6) to the drum through a ring and brush arrangement. When the drying process is complete, the dried seeds are collected from a dumping outlet.

#### RESULTS AND DISCUSSION

All measurements were done with the constant fan capacity. The experiments were carried out with barley seeds of initial humidity 17.8 %, rye seeds of initial humidity 17.7 % and oat seeds of initial humidity 20.5 %. A series of five tests were conducted at temperatures 323, 328, 333 K and drying chamber voltages of 0, 11 and 22 kV. In total 135 tests were carried out. The averaged results of the tests are presented in Table 1.

The barley drying experiments indicated energy savings only at the drying temperature 323 K. The energy saving  $q_{\%}$  was positive: 11.81 and 12.90 % at both supply voltage values but the other effect was observed at higher temperatures, which suggests no beneficial effect of the electrostriction forces on the seed humidity fall-off. In the case of rye, the beneficial effect of the electric field was noticed at the temperatures 323 and 333 K, but

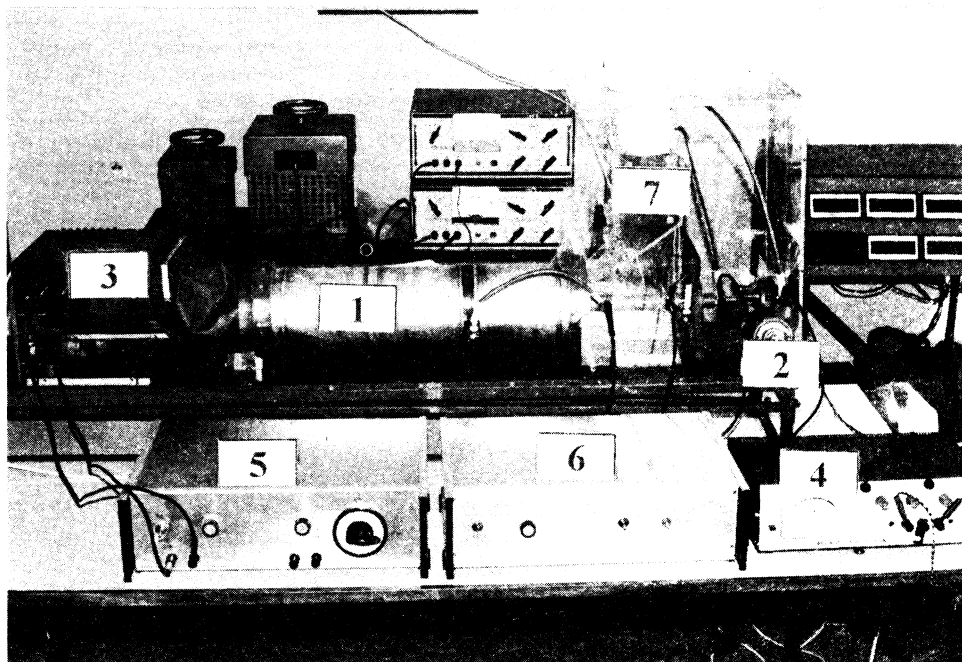

Fig. 3. The general layout of the laboratory stand and the drum drier. 1 - drying chamber (a drum), 2 - drying chamber drive, 3 - air heater, 4 - drying chamber drive supplier, 5 - heating unit supplier, 6 - high voltage supplier, 7 - charging hopper box.

there was no energy savings at 328 K.

Allowable drying period that enables the seeds to maintain their germination power depends on the humidity of the sample and the temperature of the drying medium. The drying

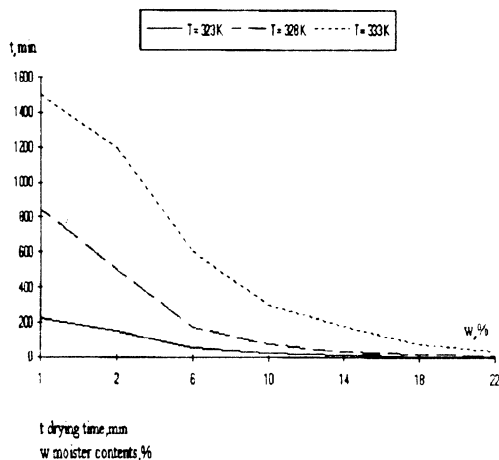

Fig. 4. Drying process time and temperature vs. humidity of dried seeds.

time is chosen on the basis of the relationship given by Eq.(3), [4]:

$$T_{z_{\max}} = \frac{23.5}{c} + (20 - \lg t) \quad (3)$$

where  $T_{z_{\max}}$  is max. drying temperature, K;  $c$  - seed specific heat, J/kg K;  $t$  - time, s.

The drying curve, presented in Fig. 4, enables the proper selection of the drying time.

The statistic analysis (t-Student test for means at the significant level 0.95) was done to determine whether statistically significant differences during the drying with or without the electric field existed. To calculate energy savings the following formula Eq.(4) can be used:

$$q_{\%} = \left[ \frac{(w-w_2)(1-w_1)}{(w-w_1)(1-w_2)} - 1 \right] 100, \% \quad (4)$$

where  $w$  is humidity of grain before drying,  $w_1$  - humidity of grain after drying without the electric field,  $w_2$  - humidity of grain after drying with influence of the electric field.

**Table 1.** Experimental averaged results

Item	Grain seeds	Drying temperature	Voltage between the electrodes	Average moisture content after drying	Energy saving
		(K)	(kV)	(%)	(%)
1	barley $w_p = 17.8\%$	323	0	14.87	-
2			11	14.51	11.81
3			22	14.48	12.90
4		328	0	14.52	-
5			11	14.76	-7.06
6			22	14.56	-1.17
7		333	0	14.68	-
8			11	14.97	-8.86
9			22	14.79	-6.76
10	rye $w_p = 17.7\%$	323	0	14.09	-
11			11	14.04	1.22
12			22	14.04	1.22
13		328	0	14.53	-
14			11	14.73	-6.15
15			22	14.88	-10.86
16		333	0	15.69	-
17			11	15.89	-9.7
18			22	15.84	-7.3
19	oats $w_p = 20.5\%$	323	0	12.96	-
20			11	12.76	2.42
21			22	12.58	4.58
22		328	0	13.64	-
23			11	13.48	2.14
24			22	13.12	6.94
25		333	0	14.94	-
26			11	14.88	0.97
27			22	14.89	0.78

$w_p$  - initial humidity.

The above formula is right because: the initial humidity was the same at each sample either with or without electrical field, the mass of each sample was the same, fan capacity was constant, and all drying processes were carried at the same temperature

The results indicate the maximum beneficial effect of the electrostriction forces on the seed of humidity 18 % at the temperatures lower than 328 K. The increase of drying temperature minimizes the influence of these forces or even causes humidity retention in the seeds.

The drying of the high humidity seeds (oat humidity about 20 %) brings better results (energy saving) within the whole temperature range. The drying with the electric field is recommended for the seeds of higher humidity.

#### CONCLUSIONS

The conclusions based on the results of the present work are as follows:

1. Tarushkin's hypothesis that positive and negative tensile stresses arising in an electrostatic field can make microchanges in grain

structure has been proved. The effect of these changes can be observed as reduction in moisture retention capacity and thereby lower energy consumption than in conventional drying processes.

On the basis of this research we can find out that there are certain values of the electrical field intensity for which we can see energy saving in drying grain seeds. The electrostatic field has then a mechanical influence on the grain structure.

2. The electrical field intensity value is significant in the energy saving aspect of the process.

3. The saving in energy consumption, arising from the presence of an electrical field in a

drying process decays at temperature values higher than 325 K.

#### REFERENCES

1. **Baran J.:** Influence of some material properties on electrostrictive effects within a dielectric model of grain. Proc. Int. Cong. Agric. Eng., Dublin, 2205-2210, 1989.
2. **Johnk Carl T.A.:** Engineering Electromagnetic Fields and Waves. John Wiley & Sons, 1975.
3. **Krakowiak J., Pietrzyk W.:** Utilization of strong electrostatic field in drying process. Proc. Int. Symp. High Voltage Eng., Dresden, 37-38, 1991.
4. **Pabis S.:** Drying crops (in Polish). PWR i L, Warszawa, 1965.
5. **Tarushkin W.I.:** The action of ponderomotor forces on grain during separation (in Russian). Mech. Elektr. Selsk. Hoz., 12, 35-39, 1983.