

APPLICATION OF AN INDUCTIVE CONVERTER FOR MEASURING THE THICKNESS OF ANTI-CORROSION COATINGS IN MACHINES

Paweł Ptak^{*}, Tadeusz Złoto^{**}

^{*}Institute of Telecommunications and Electromagnetic Compatibility

^{**}Institute of Machine Technology and Production Automation
Częstochowa University of Technology

Summary. The paper deals with measuring the thickness of anti-corrosion coatings. We discuss anti-corrosion treatments and various methods of testing them as well as present factors affecting measuring errors of inductive converters. Then, we describe the operation of a transformer inductive converter applied to measuring the thickness of selected anti-corrosion coatings.

Key words: inductive converters, anti-corrosion coating, measuring methods

INTRODUCTION

Corrosion is a problem affecting practically all branches of industry. Despite using more and more effective anti-corrosion treatments corrosion damages are still the most frequent causes of failure or aggravating technological parameters in many machines, devices, or constructions. Non-destructive tests of corrosion damages can contribute significantly towards assessing the technological condition of machines and construction while they are being in use. There exist a number of methods of protecting metallic elements from corrosion, including surface treatments (zinc plating, painting, bitumen coating, and others). Coatings applied for protective or decorative reasons should meet desired parameters of quality, thickness, resistance and looks. Measurements of the thickness of surface coatings are applied in automotive, electronic, metallurgical, plastic, telecommunications, aviation and food industries.

Various types of anti-corrosion treatments have to meet detailed standards concerning their properties, thickness, and testing methods. The method of applying the coating, its thickness, acceptable deviation, and measurements are determined in the technological process. Measurements can be performed by means of a number of devices and methods, which are selected depending on the specific conditions and requirements, such as access to the surface examined and properties of the substrate and coating [Beamish 2000; Biestek, Sękowski 1973; Górecka, Polański 1983; Petrilli 2001].

The measurement methods can be divided into destructive and non-destructive. Destructive methods are more universal and in many cases advantageous, whereas non-destructive methods are

recommended for measuring coating thickness when it is not possible to take a coating sample, or when destroying the coating is not advisable.

The non-destructive methods include magnetic, electromagnetic, inductive, and eddy-current testing. Most thickness gauges typically employ the eddy-current method or inductive methods. One of the most popular gauges is a transformer inductive converter used for measuring the thickness of conducting and non-conducting surface coatings on ferromagnetic substrates [Bronkiewicz, Janiczek, Ptak 2005; Bronkiewicz, Ptak 2005; Lewińska-Romicka 2001a; Lewińska-Romicka 2001b; Petrilli 2001].

APPLICATION OF THE INDUCTIVE CONVERTER FOR MESURING THE THICKNESS OF ANTI-CORROSION COATING

An inductive converter may have a single coil, in which case it is a choke converter, or two or more coils, in which case it is a transformer converter. The windings on the ferromagnetic core are elements of the choke (current transformer) with the open magnetic circuit. It is induced by alternating current of frequency from a few hundred to several thousand Hz. The magnetic circuit of the converter is closed by the coating and substrate examined, and the coating is a gap in the circuit (Fig.1). The signal coming from the inductive converter situated over the area examined depends on a number of parameters. A parameter significantly affecting the signal strength is the distance d from the surface tested [Janiczek 2006; Łapiński 1974; Senczyk 1994].

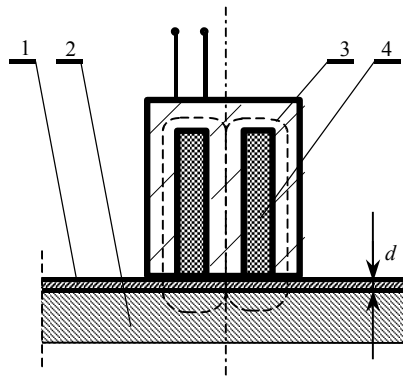

Fig. 1. Inductive converter for measuring the coating thickness; 1 - coating, 2 - substrate, 3 - magnetic flux path, 4 - windings

It can be assumed that the measuring signal corresponding to a given thickness of the coating, such as the voltage U_p for the transformer converter, depends on the quantities characterizing its construction and parameters of the element tested. The dependence can be represented as

$$U_p = f(d_w, d_p, \mu_w, \mu_p, \varepsilon_w, \varepsilon_p, f, I, z_1, z_2, k, A)$$

where

U_p - the output voltage signal of the converter,

d_w, d_p - the thickness of the coating and substrate, respectively,

μ_w, μ_p - the magnetic permeability of the coating and substrate, respectively,

- ϵ_w, ϵ_p - the permittivity of the coating and substrate, respectively,
 f - the frequency of the current power supply,
 I - the amplitude of the power supply (current) signal,
 z_1, z_2 - the number of turns in the power supply winding and in the measuring winding,
 k - the construction coefficient of the converter,
 A - the coefficient related to the dimensions and shape of the sample examined.

It can be therefore assumed that the voltage induced at the secondary winding depends on the coating thickness, magnetic permeability of the substrate, radius of the object curvature, the substrate thickness, area of measurement, coarseness of the surface and distance from the measuring site to the object edge. The output voltage of the inductive measuring converter depends on the coating thickness, electrical conductivity of the substrate, radius of the object curvature, thickness of the substrate, area of measurement, coarseness and distance from the measuring site from the object edge [Beamish 2000; Lewińska-Romicka 2001; Bronkiewicz, Janiczek 2004; May, Morton, Zhou, 2007; Rawa 2001].

FACTORS AFFECTING MEASURING ERRORS IN INDUCTIVE CONVERTERS

Measuring errors accompanying the use of transformer converters typically result from alterations in the feeding voltage and frequency, changes in temperature, non-linearity of characteristics, change in the impedance phase angle, accuracy of the instrument connected to the converter, insufficient sensitivity, or interference by electromagnetic fields. Changes in the feeding voltage and frequency can be usually avoided by using a good quality voltage generator, which is resistant to such kind of interference. Changes in temperature cause changes in the resistance of the windings and in order to eliminate them measuring systems are used with two inductive converters connected differentially. To ensure a sufficient sensitivity of the converter a small gap is used, which may, however, have negative consequences because when the gap is small, a change in its length affects significantly the converter sensitivity. Thus, the gap in the magnetic circuit cannot be too small if it undergoes large changes during the measurement, on the other hand, it cannot be too long to avoid large dissipation of magnetic flux [Bronkiewicz, Janiczek, Ptak 2005; Hull, John 1988; Janiczek, Ptak 2007; Miłek 2006]. The nonlinearity between an electric quantity and a nonelectric one, dependent on the changes in the gap length, can be reduced if the converter operation involves only small changes in the gap length. The magnetic circuits with the differential connection are not fully symmetrical, so errors may result from changes in the impedance phase angle. To minimize the risk of such errors, the two halves of the differential converter should be of identical construction and made of the same materials.

The measuring converter is but an element in the measuring chain so it is also essential to develop an appropriate computational algorithm which would yield the coating thickness.

The number of factors potentially increasing the uncertainty of the measurement is significant. The accuracy can be assessed by theoretical analysis and empirical testing of measuring converters [Biestek, Sękowski 1973; Łapiński 1974; Sajdera 2002; Wilson 2005].

TESTING THE INDUCTIVE TRANSFORMER CONVERTER

The tests of the measuring converter were performed on especially prepared samples with known thickness of the substrate and the coating. The substrates were ferromagnetic and the con-

verter was fed mainly by sinusoidal signals of various frequencies. Test with non-sinusoidal signals were also performed. The coatings were non-ferromagnetic conductors. The aim of the tests was to assess the usefulness and reliability of the measuring converter for measuring coating thickness without carrying out the full calibration procedure.

The tests were intended mainly to assess the performance of the converter on conductive coatings on ferromagnetic substrates. This type of measuring converter was originally designed to operate with amplitude signal, and such signals were mainly used in testing. Figs. 2 and 3 present the amplitudes of the measuring signal depending on the frequency for various thicknesses of aluminum platings and paints.

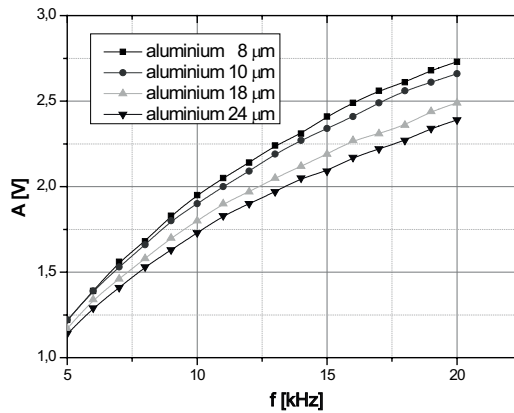

Fig. 2. Amplitudes of the measuring signal for various thicknesses of aluminum platings on 1 mm thick ferromagnetic substrate

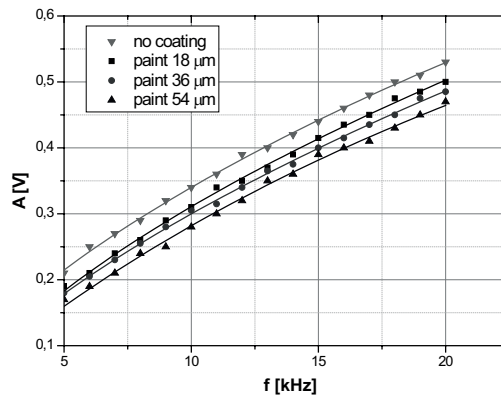

Fig. 3. Amplitudes of the measuring signal for various thicknesses of paints on 1 mm thick ferromagnetic substrate

On the basis of previous studies an instrument was designed for measuring multilayer coatings for testing and diagnostic purposes. This instrument is used for measuring the thickness of the conducting layer, e.g. zinc, together with other protective layers on power industry constructions, or on a car body in automotive industry. The total thickness of the protecting coatings can be measured

by means of the inductive method, but the thickness of the conductive layer cannot be examined in this way because it is covered by non-conductive external coatings, such as paints.

The thickness of the zinc plating under the paint layer was measured by means of the inductive transformer sensor. The tests were performed for zinc platings of 13 μm , 24 μm , 35 μm , 45 μm and 55 μm of thickness on 1mm thick ferromagnetic substrate. The thickness of the external paint was such that the total thickness of the paint and zinc plating was always 70 μm . Because of that it is known that the sensor responds only to the changes in the zinc plating thickness and not to the changes in the two-layer thickness, which is always the same. [Biestek, Sękowski 1973; Łapiński 1974; Sajdera 2002; Wilson 2005]. Fig. 4 presents the values of the voltage signal depending on the frequency for zinc coatings of various thicknesses.

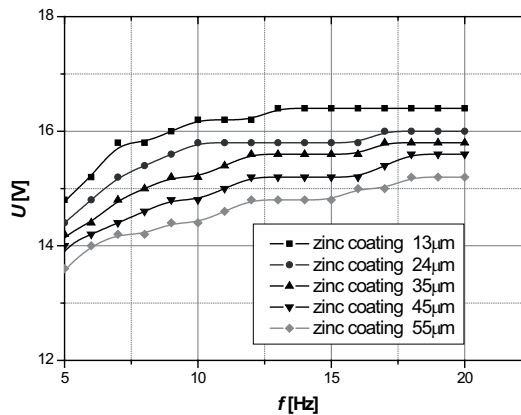

Fig. 4. Dependence of the voltage signal on the frequency for zinc coatings of various thicknesses

CONCLUSIONS

The tests performed on the inductive transformer converter lead to the following conclusions:

1. Using the inductive transformer sensor enables analysis of the zinc coating thickness. Thus, the method described can be applied for assessing corrosion in the conductive protective layer, which is not accessible for examination by means of the classical eddy-current method during exploitation. The measuring signal can be easily adjusted to the measuring probe used.
2. The inductive converter examined can be applied for measuring coatings of small thickness, as compared to the substrate thickness, with measuring signals of frequencies from 10 to 20 kHz. Since the depth of the measuring signal penetration into the coating on a ferromagnetic substrate decreases with increase in frequency, the frequency and amplitude of the signal have to be selected individually for each sample so as to maximize the measurement accuracy.

REFERENCES

Beamish D., 2000: Coating thickness measurement. Metal Finishing, Vol. 98, Issue 6.

- Biestek T., Sękowski S., 1973: Metody badań powłok metalowych. Wydawnictwa Naukowo-Techniczne, Warszawa.
- Borowik L., Ptak P., 2010: Diagnostyka i monitoring zabezpieczeń antykorozyjnych urządzeń elektroenergetycznych. Śląskie Wiadomości Elektryczne, nr 6, s. 52-55.
- Bronkiewicz A., Janiczek R., 2004: Pomiary grubości nieferromagnetycznych warstw wierzchnich na podłożu ferromagnetycznym poprzez magnesowanie podłoża. Przegląd Elektrotechniczny, nr 2, s. 80-84.
- Bronkiewicz A., Janiczek R., Ptak P., 2005: Pomiary grubości cienkich warstw. Metody i systemy komputerowe w automatyce i elektrotechnice. Wydawnictwa Politechniki Częstochowskiej, Częstochowa, s.29-32.
- Bronkiewicz A., Ptak P., 2005: Wybrane aspekty metrologiczne metody pomiaru grubości warstw wierzchnich na podłożach ferromagnetycznych. Materiały V Krajowej Konferencji PES-5 Postępy w Elektrotechnice Stosowanej, Zakopane-Kościelisko, s. 283-290
- Górecka R., Polański Z., 1983: Metrologia warstwy wierzchniej. WNT, Warszawa.
- Hull J. B., John V. B., 1988: Non-destructive testing. Macmillan Education, London.
- Janiczek R., 2006: Elektryczne miernictwo przemysłowe. Wydawnictwa Politechniki Częstochowskiej, Częstochowa.
- Janiczek R., Ptak P., 2007: Przetworniki indukcyjnościowe w pomiarach grubości warstw wierzchnich. (Inductive transducers in measurements of surface layers thickness), Wiadomości Elektrotechniczne, 1 s. 86-90.
- Lewińska-Romicka A., 2001a: Pomiary grubości powłok. Biuro Gamma, Warszawa.
- Lewińska-Romicka A., 2001b: Badania nieniszczące. Podstawy defektoskopii. WNT, Warszawa.
- Łapiński M., 1974: Pomiary elektryczne i elektroniczne wielkości nieelektrycznych. Wydawnictwa Naukowo-Techniczne, Warszawa.
- May P., Morton D., Zhou E., 2007: The design of a ferrite-cored probe. Sensors and Actuators, A 136 s. 221-228.
- Miłek M., 2006: Pomiary wielkości nieelektrycznych metodami elektrycznymi. Wyd. Politechniki Zielonogórskiej, Zielona Góra.
- Petrilli C., 2001: The basics of coating thickness measurement. Metal Finishing, Vol 99, Issue 8, August.
- Rawa H., 2001: Elektryczność i magnetyzm w technice. Wydawnictwo Naukowe PWN, Warszawa.
- Sajdera N., 2002: Thickness testing. Metal Finishing, Vol 100, Supplement 1, January.
- Senczyk D., 1994: Metody badania materiałów. Wyd. Politechniki Poznańskiej, Poznań.
- Wilson J., 2005: Sensor Technology Handbook. Newnes, An imprint of Elsevier.

ZASTOSOWANIE PRZETWORNIKA INDUKCYJNEGO DO POMIARU GRUBOŚCI POWŁOK ANTYKOROZYJNYCH MASZYN

Streszczenie. W artykule przedstawiono zagadnienia, dotyczące pomiaru grubości powłok antykorozyjnych. Omówiono sposoby zabezpieczeń antykorozyjnych maszyn oraz metody ich badania przy zastosowaniu różnorodnych metod. Przedstawiono czynniki wpływające na błędy pomiarowe przetworników indukcyjnych. Opisa-no badania przetwornika indukcyjnego transformatorowego zastosowanego do pomiarów grubości wybranych warstw antykorozyjnych.

Słowa kluczowe: przetworniki indukcyjne, powłoka antykorozyjna, metodyka pomiaru